



# HAMMER

---

## CB40

Owner: \_\_\_\_\_  
Date Purchased: \_\_\_\_\_  
Model #: \_\_\_\_\_ Serial #: \_\_\_\_\_  
Manual #: 9MHAMCB2456604

**⚠ DANGER**

*Si no entiende ingles, se prefiere que busque a alguien que interprete las instrucciones para usted.*

## Operator's Manual

Danuser LLC  
500 E. 3rd St.  
P.O. Box 368  
Fulton, MO 65251  
Tel: (573) 642-2246 Fax: (573) 642-2240  
E-mail: sales@danuser.com  
Website: www.danuser.com



Dear Owner/Operator,

Thank you for purchasing this Danuser Hammer. We appreciate your business.

Your safety as an operator of our product is very important to us. Therefore, *before* you assemble, install, operate, maintain, service, remove, or move your Danuser Hammer, read and understand this manual thoroughly. If there is anything you do not understand, immediately contact your dealer, or contact our factory direct.

Phone:	(573) 642-2246
Fax:	(573) 642-2240
E-mail:	<a href="mailto:sales@danuser.com">sales@danuser.com</a>

Your satisfaction in the performance and longevity of our product is also very important to us and can be prolonged by proper assembly, installation, operation, maintenance, service, and removal as instructed in this manual.

Thank you again for your business and for your trust in our product. Please feel free to contact us at any time for further assistance.

Sincerely,

Danuser LLC

500 E. 3rd St., P.O. Box 368, Fulton, MO 65251  
Tel: (573) 642-2246 Fax: (573) 642-2240  
E-mail: [sales@danuser.com](mailto:sales@danuser.com) Website: [www.danuser.com](http://www.danuser.com)

# Foreword

*Please read this manual thoroughly!*





**Before** you assemble, install, operate, maintain, service, remove, or move your Danuser Hammer, read this manual thoroughly. If there is anything you do not understand, immediately contact your dealer, or call our factory direct at (573) 642-2246. Powered equipment can be dangerous if not assembled, installed, operated, maintained, serviced, removed, or moved properly.

### *Warranty Registration*

To activate your warranty coverage and to provide you with efficient customer service, please fill out your WARRANTY REGISTRATION FORM. This form is included in your unit's paperwork package. If you did not complete a WARRANTY REGISTRATION FORM or did not receive one, please call Danuser LLC. Or, register online at [www.Danuser.com](http://www.Danuser.com). Your satisfaction with our product and your safety as a user of our product are both very important to us.

# Symbols

 This SAFETY ALERT symbol identifies important safety messages. Carefully read each safety message that follows. Failure to understand and obey a safety message, or recognize a safety hazard, could result in injury or death to you or others around you. The operator is ultimately responsible for the safety of himself, as well as others, in the operating area of the Hammer.

<i>Symbol</i>	<i>Meaning</i>
	This is important information for proper use of this equipment. Failure to comply may lead to premature equipment failure.
	Failure to follow these instructions may cause damage to the implement or the vehicle, or minor personal injury.
	Failure to follow these instructions may result in personal injury or death.
	Immediate hazard! Failure to understand and obey this warning is likely to result in personal injury or death.

# Table of Contents

	Page
Letter to the Owner/Operator .....	2
Foreword .....	3
Symbols .....	3
Safety .....	4
Specifications .....	6
Hydraulic Requirements .....	7
Assembly & Installation .....	8
Operation .....	11
Removal & Storage .....	11
Troubleshooting .....	12
Maintenance .....	13
Service .....	14
Parts .....	16
Decals & Safety Signs .....	20
Warranty .....	Form No. 3269

## 

**Improper operation of this Hammer can cause serious personal injury or death. Operation of this Hammer should only be done by a competent adult acting in compliance with the Operator's Manual. Since Hammer operations are beyond our control, we disclaim all liability for any damages, injuries or death which may result.**

### **WARNING**

Working with unfamiliar equipment can lead to careless injuries. Read and understand this manual and the manual for your vehicle before assembling, installing, operating, maintaining, servicing, removing, or moving this Hammer. If there is anything in this manual you do not understand, contact your dealer or Danuser LLC. The safe use of this attachment is strictly up to you, the operator. If this attachment is used, loaned, or rented by any other person, it is the owner's responsibility to make certain that the operator prior to operating:

- Reads and understands the Operator's Manuals
- Is instructed in safe and proper use
- The Hammer is designed to be operated from the vehicle seat. Keep bystanders away from the work area. Do not operate with another person in contact with any part of the Hammer.
- All operators of this attachment must read and understand this entire manual, paying particular attention to safety messages and operation instructions, prior to assembling, installing, operating, maintaining, servicing, removing, or moving the Hammer.
- Please remember it is also important that you read, understand, and follow safety signs on the attachment. Clean or replace all safety signs if they cannot be clearly read and understood. They are there for your safety as well as the safety of others. Danuser LLC will furnish new safety signs upon request at no charge.
- All things with moving parts are potentially hazardous. There is no substitute for a cautious, safe-minded operator who recognizes potential hazards and follows reasonable safety practices.
- Personal protection equipment including hard hat, safety glasses, safety shoes, gloves, and ear plugs are recommended during assembly, installation, operation, maintenance, service, removal, or movement of the attachment.
- Exposure to silica dust and other dust hazards can cause serious or fatal respiratory disease. Use appropriate respiratory protection.
- When the use of hand tools is required to perform any part of assembly, installation, operation, maintenance, or service of the attachment, be sure the tools used are designed and recommended by the tool manufacturer for that specific task.
- Never check pressurized system for leaks with your bare hand. Wear proper hand and eye protection and use wood or cardboard when searching for suspected leaks. Oil escaping from pinhole leaks under pressure can penetrate skin and create a serious medical emergency. If any fluid is injected into the skin, gangrene, blood poisoning, even death may result. Obtain medical attention immediately.
- Always use two people to handle heavy, unwieldy components during assembly, installation, maintenance, service, removal, or movement of the Hammer.
- Never place any part of your body where it would be in danger if movement should occur during assembly, installation, operation, maintenance, service, removal, or movement of the Hammer.
- Only properly trained people should operate this equipment. Do not allow anyone who has not read this entire manual and understands the safety rules, safety signs, and operation instructions to use this attachment.
- Never allow children to operate or be around the Hammer.
- Do not allow riders on the equipment at any time. There is no safe place for any riders.

# Safety

---

(continued)

- Never use alcoholic beverages or drugs which can hinder alertness or coordination while operating this equipment. Consult your doctor about operating this equipment while taking prescription medications.
- Consult local utility companies to make certain there are no buried gas lines, electrical cables, etc., in the work area before beginning operation.
- Stay away from power lines when transporting, raising, or operating the Hammer.
- Before you operate the attachment, check over pins and connections to be sure all are securely in place. Make sure the Hammer is securely latched to the vehicle.
- Keep hands, feet, hair, jewelry, and clothing away from all moving and/or rotating parts.
- Never place yourself between the vehicle and the attachment.
- Never allow anyone under the attachment at any time.
- Keep clear of the Hammer while in operation.
- Do not exceed the vehicle's rated operating load. Use sufficient counterweights. Move the vehicle slowly when the attachment is raised.
- Carry the load low. A heavy load can cause instability of the vehicle. Use extreme care during travel. Slow down on turns and watch out for bumps. Use all safety devices, including a seat belt, as recommended in the vehicle operator's manual.
- Do not operate the Hammer on steep hillsides. When operating the Hammer on uneven or hilly terrain, position the vehicle with the attachment uphill. With the attachment downhill, the vehicle could tip when attempting to raise the attachment. Consult your vehicle operator's manual for maximum incline allowable.
- Always shut off the vehicle engine and remove the key before dismounting the vehicle, adjusting the attachment, or servicing the Hammer. Never leave equipment unattended with the vehicle running.
- Never attempt repairs or adjustments while the equipment is in operation.
- Before disconnecting hydraulic lines or fittings be sure to relieve all pressure by cycling all hydraulic controls after shutdown. Remember hydraulic systems are under pressure whenever the engine is running and may hold pressure after shutdown.
- Always use care when operating the Hammer. Most accidents occur because of neglect or carelessness.

Safety is a primary concern in the design, manufacture, sale, and use of Hammers. Danuser confirms to you, our customer, our concern for safety.

# Specifications

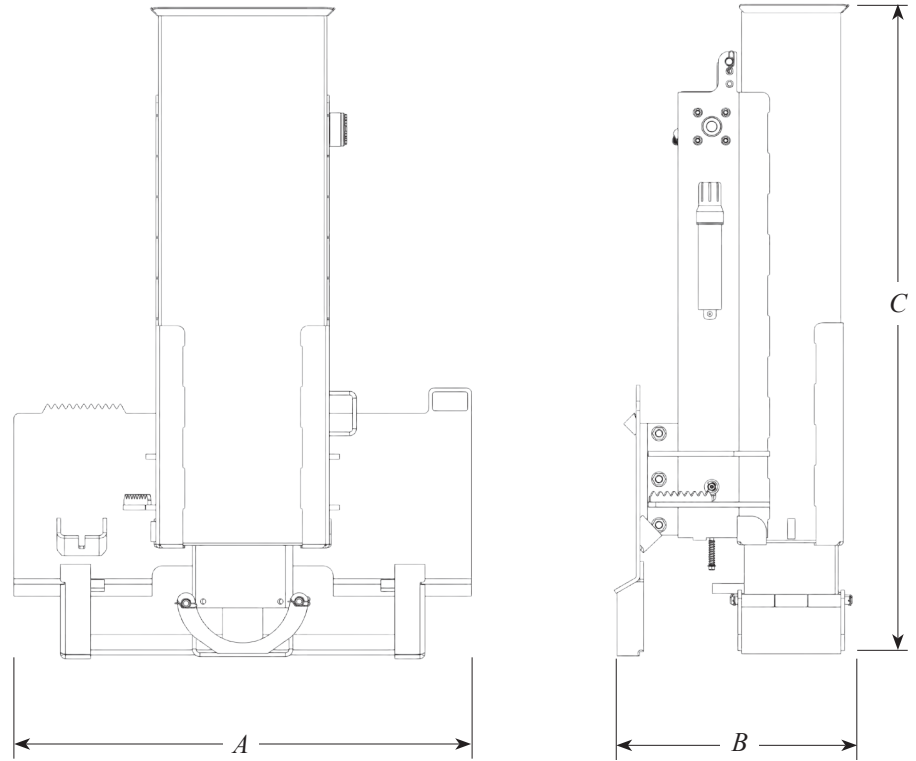

	<b>Model CB40</b>
Overall Length (A)	45.5"
Overall Width (B)	25"
Overall Height (C)	64"
Breaker Weight	500 lbs.
Length of Stroke	40"
Max. Strokes Per Minute	35
Hydraulic Requirements	1500-3000 PSI Up to 30 GPM
Maximum Concrete Thickness	9"
Impact Force	82000 lbs.
Impact Energy	1709 ft.-lbs.

# Hydraulic Requirements

---

## Filtration Requirements:

- A filter of, at least, 25 micron filtration is required. A filter capable of 10 micron filtration is preferred. The majority of paper type filters are 25 microns or better.

### NOTE

The life of the hydraulic motor is almost entirely dependent upon cleanliness of the oil. Instructions in your vehicle operator's manual regarding filter and oil changes should be carefully followed. Even small amounts of dirt in the hydraulic oil can cause premature motor failure that is not covered by warranty.

- A low pressure type filter can be installed in the return line from the control valves to the sump. A low pressure type filter can, also, be installed in the sump or pump intake line, but must be sized large enough to avoid starving the pump.
- A high pressure type filter can be used between the pump and the control valves.
- If the source of the hydraulic power does not have a filter, it will be necessary to install one at some point in the system so, at least, part of the hydraulic oil is being filtered whenever the system is operating. After a filter is installed and before attaching the Hammer, the entire hydraulic system should be drained, filled with new oil, and operated for 30 minutes or until the system is warm. During this run time, operate all valves, cylinders, and hydraulic motors on the attachment.

## Pressure and Flow Requirements:

- The Hammer is designed to operate up to 30 GPM and 1500 – 3000 PSI.

## Valve Requirements:

- The hydraulic system used to power the Hammer should be equipped with a four-way valve large enough to carry full pump outlet without restricting flow and causing oil heating.
- The four-way valve requires a relief valve which will open and relieve extreme pressures between the Hammer and control valve, even when the control valve is in a neutral position. This feature can be obtained by connecting two external relief valves between the main lines running from the control valve to the Hammer in such a way that high pressure in either line will be relieved to the other line.

## Hydraulic Fluid Selection Requirements:

- Premium grade petroleum based fluids will provide the best performance.
- Fluids that contain anti-wear agents, rust inhibitors, anti-foaming agents, and oxidation inhibitors are recommended.
- The viscosity of the fluid should never fall below 70 SUS (13 cST). The best viscosity range of the Hammer is 100-200 SUS (20-43 cST).

# Assembly & Installation

Retention Pin

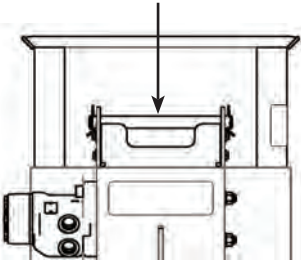

## ⚠ WARNING

Personal protection equipment including hard hat, safety glasses, safety shoes, gloves, and ear plugs are recommended during assembly, installation, operation, maintenance, service, removal, or movement of the attachment.

## ⚠ CAUTION

Because of the weight of some components, and because some components are difficult to balance, two people are required for safe assembly and installation of this equipment.

### Concrete Breaker Kit Option

To convert a Hammer post driver to a Hammer concrete breaker, follow the instructions below.

- STEP 1: Ensure the Hammer is sitting on a level surface and the parking stand is in the down position.
- STEP 2: Make sure the hammer weight catch is visible through the viewing slots on the back of the case.
- STEP 3: Remove the retention pin from the top of the case. Insert a hook into the lifting eye located on the top of the weight. Lift the weight out of the Hammer with a hoist, forklift, or another vehicle. Set the weight on the ground.

## ⚠ WARNING

**Do not tilt or operate the Hammer without the retention pin in place. The hammer weight could slide out of the Hammer and cause serious injury or death.**

- STEP 4: Reinstall the retention pin. Connect a hook or lifting strap onto the retention pin and lift the Hammer using a hoist, forklift, or another vehicle, until it is completely off the ground.
- STEP 5: Using your hands, carefully remove the strike plate by pushing it up, tilting it toward you, and pulling it out.
- STEP 6: Remove the pin (PN 21079) attaching the foot to the Hammer and set aside. Remove the foot. Hammers equipped with a grapple will not have a foot.
- STEP 7: Remove the rue clips (PN 21078) and pin (PN 21207) attaching the parking stand (PN 21208) to the Hammer and set the rue clips aside. Remove the parking stand and parking stand retention pin (PN 21206).

If the Hammer is equipped with the grapple option, it must be removed prior to using the concrete breaker attachment. Follow the instructions below for removing the grapple. If you do not have the grapple option, continue to Step 9.

- STEP 8: Remove the pin (PN 21079) and spring attaching the grapple to the Hammer and set aside. Remove grapple hydraulic hoses (PN 21143 & 21144) from the manifold and plug the holes.

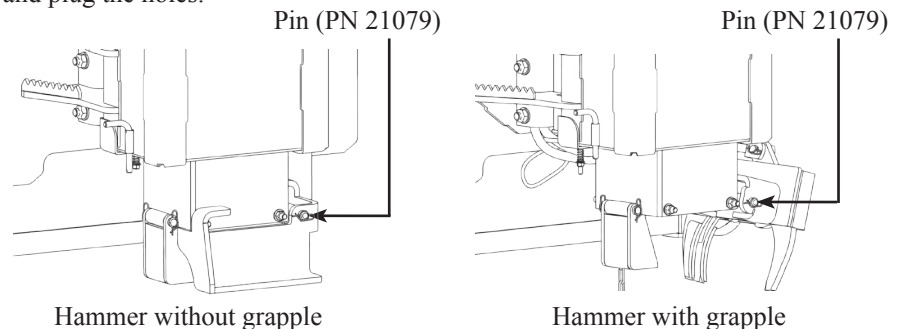

## ⚠ WARNING

**Remember hydraulic systems are under pressure whenever the engine is running and may hold pressure after shutdown. Before connecting or disconnecting hydraulic hoses, be sure to relieve all pressure by cycling all hydraulic controls after shutdown.**

# Assembly & Installation

(continued)

STEP 9: Install the new breaker foot assembly using the existing pin (PN 21079), the new pin (PN 21079) provided with the breaker kit, and the four rue clips (PN 21078). One set of holes on the foot is lower than the other set. Make sure to align side A, the side with the oval holes slightly lower than B, and the two spacers (PN 21277) with the left side of the machine when looking at the front of the Hammer. Install the two pins and rue clips to hold the foot in place.

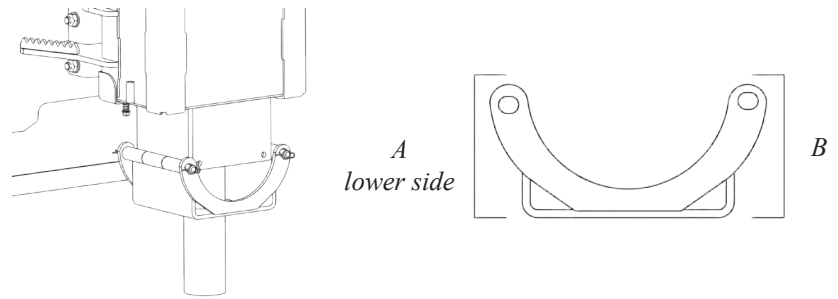

STEP 10: Lower the Hammer back to the ground and remove the retention pin.

STEP 11: Insert a hook into the lifting eye located on the top of the breaker weight. Lift the breaker weight with a hoist, forklift, or another vehicle.

STEP 12: Lower the breaker weight into the Hammer and reinstall the retention pin .

## **! WARNING**

**Do not tilt or operate the Hammer without the retention pin in place. The breaker weight could slide out of the Hammer and cause serious injury or death.**

STEP 13: Install the three safety signs included with the breaker kit.

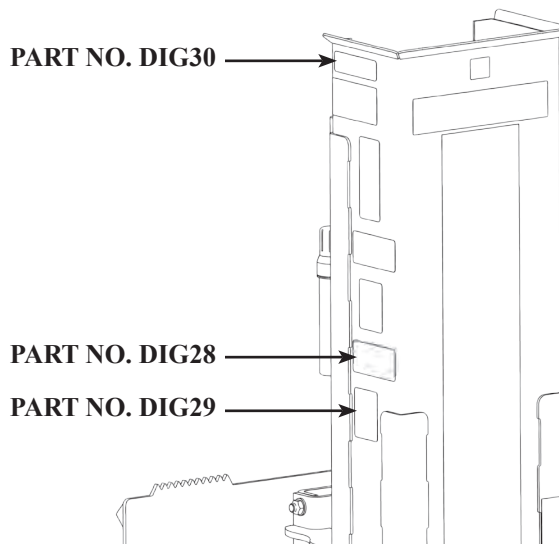

### **CB40 Installation - Prepare the Vehicle**

Read and understand the manual for your vehicle before assembling or installing the Hammer. The vehicle must be equipped with a universal quick attach hitch and auxiliary hydraulics. The use of the Hammer may require the addition of counterweights to ensure the attachment does not exceed the rated capacity of the vehicle.

## **! DANGER**

**Do not exceed the vehicle's rated operating load. If necessary, use sufficient counterweights.**

# Assembly & Installation

(continued)

Retention Pin

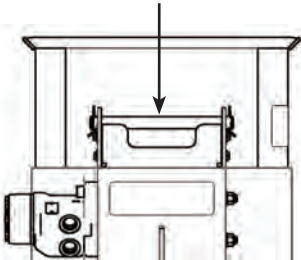

## ⚠ WARNING

Personal protection equipment including hard hat, safety glasses, safety shoes, gloves, and ear plugs are recommended during assembly, installation, operation, maintenance, service, removal, or movement of the attachment.

## ⚠ CAUTION

Because of the weight of some components, and because some components are difficult to balance, two people are required for safe assembly and installation of this equipment.

STEP 1: Install the Hammer by following your vehicle operator's manual for installing an attachment.

## ⚠ WARNING

**Make sure the Hammer is securely latched to the vehicle. Failure to do so could result in separation of the attachment from the vehicle.**

STEP 2: Route the hydraulic hoses through the quick attach plate hose holder, and connect the hydraulic hoses to the vehicle's auxiliary hydraulics.

## ⚠ WARNING

**Remember hydraulic systems are under pressure whenever the engine is running and may hold pressure after shutdown. Before connecting or disconnecting hydraulic hoses, be sure to relieve all pressure by cycling all hydraulic controls after shutdown.**

STEP 3: Ensure the retention pin is in place. The retention pin prevents the breaker weight from sliding out of the Hammer.

## ⚠ WARNING

**Do not operate the Hammer without the retention pin in place. The breaker weight could slide out of the Hammer and cause serious injury or death.**

STEP 4: Shut off the vehicle engine.

STEP 5: Oil the Hammer drive chain, and grease all zerks.

STEP 6: Start the vehicle. Raise the loader arms until the breaker weight is completely off the ground. Engage the auxiliary hydraulics. Note the direction of the chain rotation (visible from the operator's seat). The breaker weight catch should be rotating from the top to the bottom. If the chain is not rotating at all, reverse the hydraulic hoses.

## ⚠ WARNING

**Remember hydraulic systems are under pressure whenever the engine is running and may hold pressure after shutdown. Before connecting or disconnecting hydraulic hoses, be sure to relieve all pressure by cycling all hydraulic controls after shutdown.**

STEP 7: Check the hydraulic system for leaks.

## ⚠ WARNING

**Never check pressurized system for leaks with your bare hand. Wear proper hand and eye protection and use wood or cardboard when searching for suspected leaks. Oil escaping from pinhole leaks under pressure can penetrate skin and create a serious medical emergency. If any fluid is injected into the skin, gangrene, blood poisoning, even death may result. Obtain medical attention immediately.**

## Operation

---

### DANGER

The Hammer is designed to be operated from the vehicle seat. Keep bystanders away from the work area. Do not operate with another person in contact with any part of the Hammer.

### DANGER

Stay away from power lines when transporting, raising, or operating the attachment.

## Removal & Storage

---

### WARNING

Personal protection equipment including hard hat, safety glasses, safety shoes, gloves, and ear plugs are recommended during assembly, installation, operation, maintenance, service, removal, or movement of the attachment.

### DANGER

Before you operate the attachment, check over pins and connections to be sure they all are securely in place. Make sure the Hammer is securely latched to the vehicle.

### DANGER

Consult local utility companies to make certain there are no buried gas lines, electrical cables, etc., in the work area before beginning operation.

- STEP 1: Move the vehicle into position with the loader arms raised and the Hammer positioned directly over the concrete to be broken.
- STEP 2: Lower the Hammer until it is approximately two to three inches (2"-3") off of the concrete. This means the breaker weight will be slightly pushed up into the housing.
- STEP 3: The Hammer can now be activated by turning the auxiliary hydraulics to forward position.
- STEP 4: Once the concrete is broken, continue to cycle the breaker weight as the vehicle is repositioned. For best results, move back three to six inches (3"-6") at a time. Be sure to stop the vehicle before the breaker weight drops again.

#### NOTE

Depending on the thickness and strength of the concrete, it may take two or more hits to fracture.

- STEP 5: Continue until all concrete has been broken.

#### NOTE

When stopping the Hammer, the breaker weight catch should be visible through the viewing slots on the back of the case. Never stop the Hammer with the breaker weight partially raised.

Before storage, the Hammer should be thoroughly cleaned, washing off all dirt and grime. Lubricate the drive chain, and grease all zerks. Make sure the hydraulic system is properly sealed against contaminants entering the unit. Always store the Hammer in a dry, covered location.

- STEP 1: Lower the Hammer onto a flat, level surface.

### DANGER

Never allow anyone under the attachment at any time.

- STEP 2: Shut off the vehicle engine, lower the arms, relieve all hydraulic pressure (by activating the vehicle controls), and remove the vehicle key before leaving the vehicle seat.

### WARNING

Before disconnecting hydraulic lines or fittings be sure to relieve all pressure by cycling all hydraulic controls after shutdown. Remember hydraulic systems are under pressure whenever the engine is running and may hold pressure after shutdown.

# Removal & Storage

(continued)

STEP 3: Disconnect the hydraulic hoses from the vehicle's auxiliary hydraulics.

**NOTE**

Connect the quick couplers together to prevent contaminants from entering the Hammer hydraulic system.

STEP 4: Follow your vehicle operator's manual for removing an attachment.

# Troubleshooting

PROBLEM	POSSIBLE CAUSE	SOLUTION
Weight is dropping unexpectedly	a. Weight is not down after breaking	When finished breaking, make sure weight is down and/or catch is visible through viewing slots. Refer to Operation section of manual.
Weight not cycling	a. Hammer is not lowered to the ground	The breaker weight must be pushed up inside the Hammer until it stops before the weight will cycle.
	b. Broken or missing shaft key	Replace key.
	c. Channel is not lubricated	Grease the inside of the Hammer case.
	d. Motor damaged	Contact Danuser.
Motor will not operate	a. Motor damaged	Contact Danuser.
	b. Incorrect hose routing	Refer to Hydraulics section of manual for proper hose routing.
Chain jumps	a. Incorrect chain tension	Adjust chain tension.
	b. Sprockets or chain are worn	Replace worn item(s).
Oil over heating	a. High flow activated	Ensure vehicle is not in high flow mode.
	b. Low oil level	Fill reservoir to proper level.
	c. Dirty oil or oil filter	Change oil and filter.

*For additional assistance, please call your dealer or contact Danuser direct:*

*Phone: (573) 642-2246*

*Fax: (573) 642-2240*

*E-mail: sales@danuser.com*

# Maintenance

## **WARNING**

**Personal protection equipment including hard hat, safety glasses, safety shoes, gloves, and ear plugs are recommended during assembly, installation, operation, maintenance, service, removal, or movement of the attachment.**

## DAILY

### **CHECK FOR CLEAN HYDRAULIC OIL**

The majority of all hydraulic component failures are caused by contamination of the hydraulic oil. At all times, keep dirt and other contaminants from entering the hydraulic system during connecting and disconnecting the hydraulic system. Always use dust caps and plugs on all quick disconnects when not in use.

### **CHECK ALL HYDRAULIC HOSE ASSEMBLIES**

Check for cracked or brittle hoses. Replace hoses immediately if cracked or brittle. Replacement of hoses before failure will prevent loss of hydraulic oil, hydraulic oil contamination, and component damage caused by cavitation.

### **CHECK ATTACHMENT AND ALL ACCESSORIES**

Check all bolts and fasteners for tightness. Visually inspect the attachment for damage.

## EVERY 40 HOURS

### **GREASE ZERKS**

Grease the zerk on the drive chain bearing. Grease the zerk on the bottom chain sprocket shaft.

### **LUBRICATE ATTACHMENT**

Grease the inside of the Hammer case. Lubricate the drive chain with a high quality commercial grade chain lubricant.

### **CHECK ATTACHMENT AND ACCESSORIES**

Visually inspect all welds for cracks. Check the chain catch for wear. Check all bolts and fasteners for tightness.

### **CHECK CHAIN TENSION**

Inspect the chain tensioning springs. Springs should be preloaded but not entirely collapsed.

## Service

Retention Pin

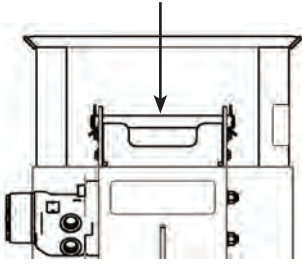

### **⚠ WARNING**

Personal protection equipment including hard hat, safety glasses, safety shoes, gloves, and ear plugs are recommended during assembly, installation, operation, maintenance, service, removal, or movement of the attachment.

### **⚠ CAUTION**

Because of the weight of some components, and because some components are difficult to balance, two people are required for safe assembly and installation of this equipment.

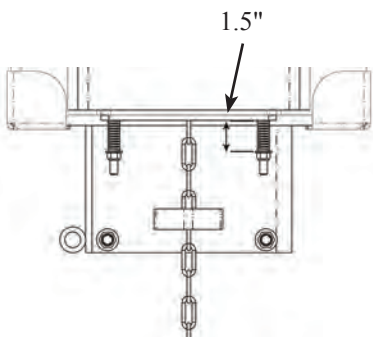

Tighten tensioning nuts until springs are adequately preloaded

### **⚠ DANGER**

Never attempt repairs or adjustments while the equipment is in operation.

#### **Replacing the Drive Chain**

- STEP 1: Make sure the breaker weight catch is visible through the viewing slots on the back of the case.
- STEP 2: Remove the retention pin from the top of the case. Insert a hook into the lifting eye located on the top of the weight. Lift the weight out of the Hammer with a hoist, forklift, or another vehicle. Set the weight on the ground.
- STEP 3: Carefully lay down the Hammer on its front side.
- STEP 4: Remove the top and bottom chain covers.
- STEP 5: Remove the retaining ring fastened to the lower sprocket shaft assembly, and pull out the shaft from the opposite side of the Hammer.
- STEP 6: Remove the tensioning rods and shim(s). Slide chain slack to the top of the Hammer.
- STEP 7: Find the chain catch and two pins that secure it. Remove the clips that retain the pins, and remove the pins.
- STEP 8: Install new chains over the upper sprocket shaft assembly. Make sure open ends of the chain are at equal links away from sprockets.
- STEP 9: Reinstall the chain catch and pins through the open ends of the new chain. Install clips on the pins.
- STEP 10: Slide chain slack to the bottom of the Hammer, and insert the lower sprocket shaft assembly into the chain.
- NOTE** Shim(s) must be inserted between the tensioning rods and the lower sprocket shaft assembly to maintain proper sprocket location.
- STEP 11: Insert the lower sprocket shaft through the side of the Hammer and through the tensioning rods and sprockets.
- STEP 12: Install shim(s) and retaining ring on the end of the sprocket shaft.
- STEP 13: Install bottom chain guard and tensioning springs. Tighten tensioning nuts until the springs are adequately preloaded but not entirely collapsed.
- STEP 14: Install the top chain cover, stand Hammer upright, reinstall weight, and install the retention pin.

### **⚠ WARNING**

Do not operate the Hammer without the retention pin in place. The breaker weight could slide out of the Hammer and cause serious injury or death.

This page is intentionally blank.

# Parts

 = Safety Sign Location

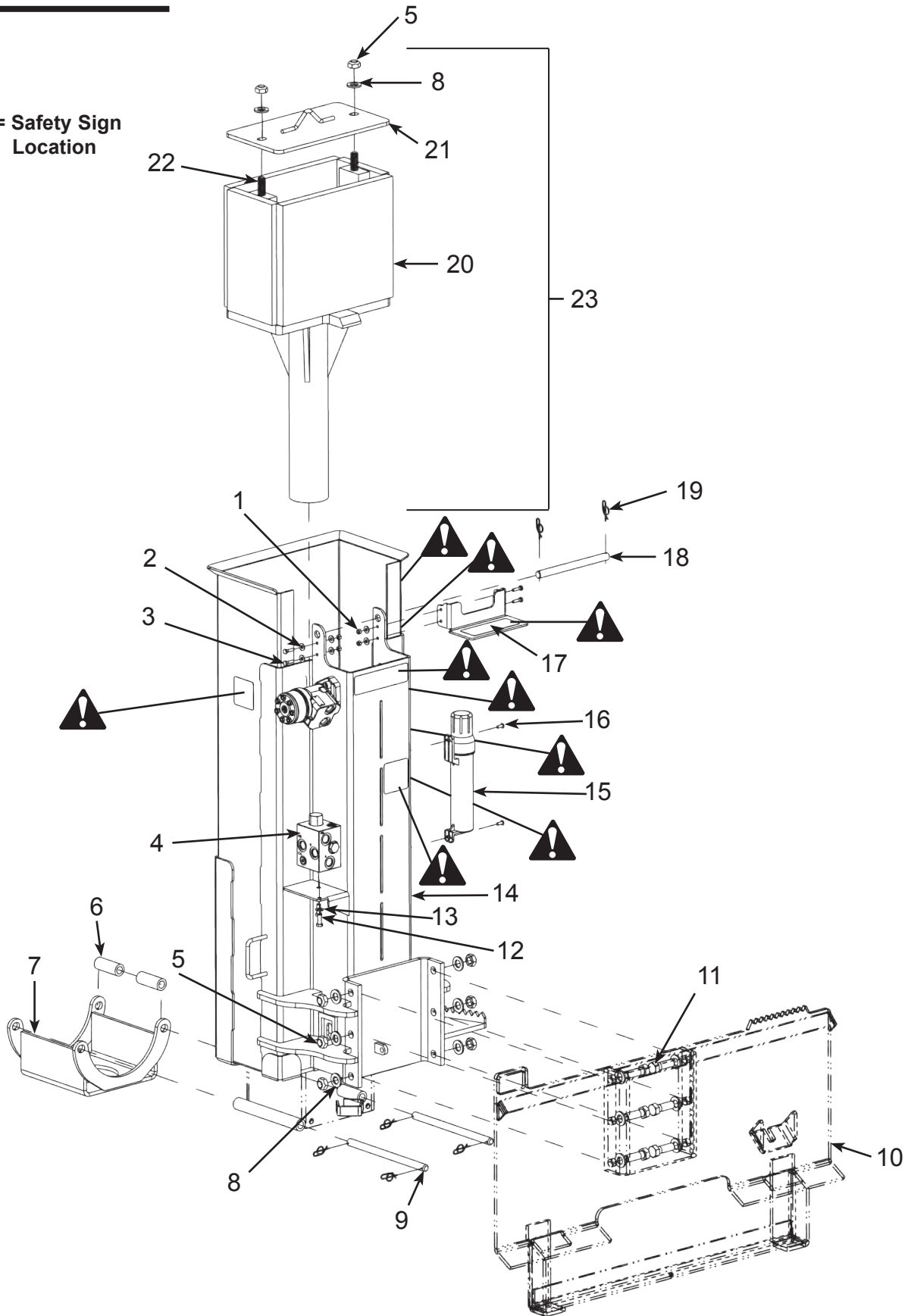

## Parts

(continued)

REF. NO.	PART NO.	DESCRIPTION	QTY.
1	10195	Toplock Nut (1/4"-20)	4
2	21056	1/4" Flat Washer	4
3	21055	Bolt (1/4"-20 x 1")	4
4	21137	Hydraulic Manifold	1
5	10267	Toplock Nut (3/4"-10)	8
6	21277	Boss	2
7	21274	Foot	1
8	10268	3/4" Flat Washer	8
9	21079	Pin	2
10	21086	Quick Attach Plate	1
11	21105	Bolt (3/4"-10 x 2-1/4" Gr. 5)	6
12	21157	Bolt (3/8"-16 x 1")	2
13	2178	3/8" Flat Washer	2
14	21026	Case	1
15	21258	Canister	1
16	21259	Drive Rivets	2
17	21133	Cover	1
18	21118	Retention Pin	1
19	21078	Rue Clip	6
20	21271	Weight	1
21	21052	Weight Cover	1
22	21054	Stud (3/4"-10 x 3-1/4")	2
23	21270	Weight Assembly (consists of items 5, 8, 20, 21, and 22)	1

# Parts

## Drive Assembly

 = Safety Sign Location

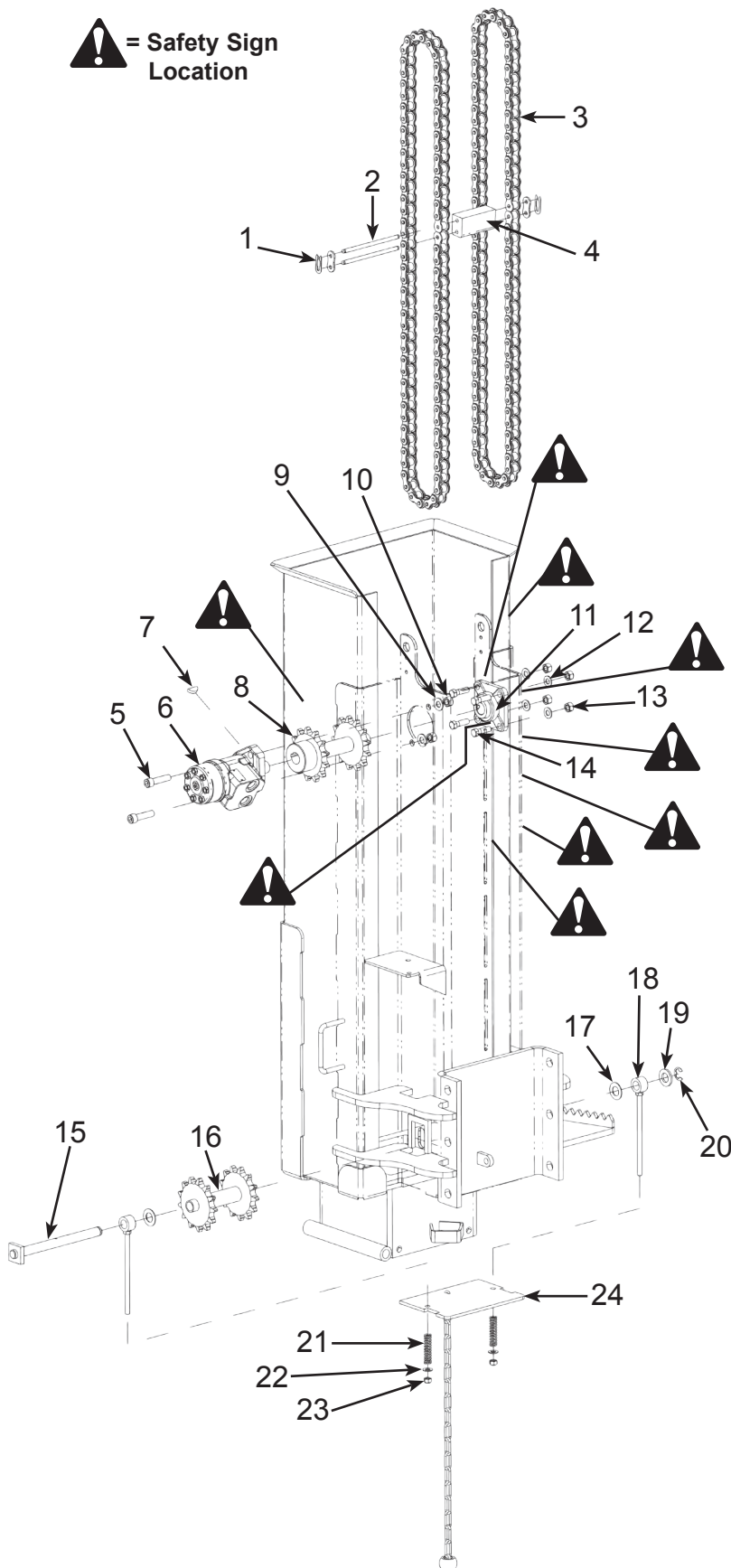

REF. NO.	PART NO.	DESCRIPTION	QTY.
1	21119	Connecting Link	2
2	21024	Chain Pin	2
3	21025	Roller Chain #80, 1" Pitch	2
4	21122	Catch Weight	1
5	21126	Socket Head Bolt (1/2"-13 x 2")	2
6	21113	Hydraulic Motor (includes item 7)	1
7	21281	Motor Shaft Woodruff Key	1
8	21114	Upper Sprocket Shaft Assembly	1
9	21156	1/2" Flat Washer	2
10	10125	Toplock Nut (1/2"-13)	2
11	21043	Bearing	1
12	2489	7/16" Flat Washer	4
13	10197	Toplock Nut (7/16"-14)	4
14	21057	Bolt (7/16"-14 x 1-1/2")	4
15	21040	Sprocket Shaft	1
16	21080	Lower Sprocket Shaft Assembly	1
17	21125	Shim	2
18	21083	Tensioning Rod	2
19	10267	3/4" Flat Washer	1
20	2172	Retaining Ring	1
21	21123	Spring	2
22	2178	3/8" Flat Washer	2
23	10412	Toplock Nut (3/8"-16)	2
24	21110	Cover Assembly	1

# Parts

## Hydraulics

 = Safety Sign Location

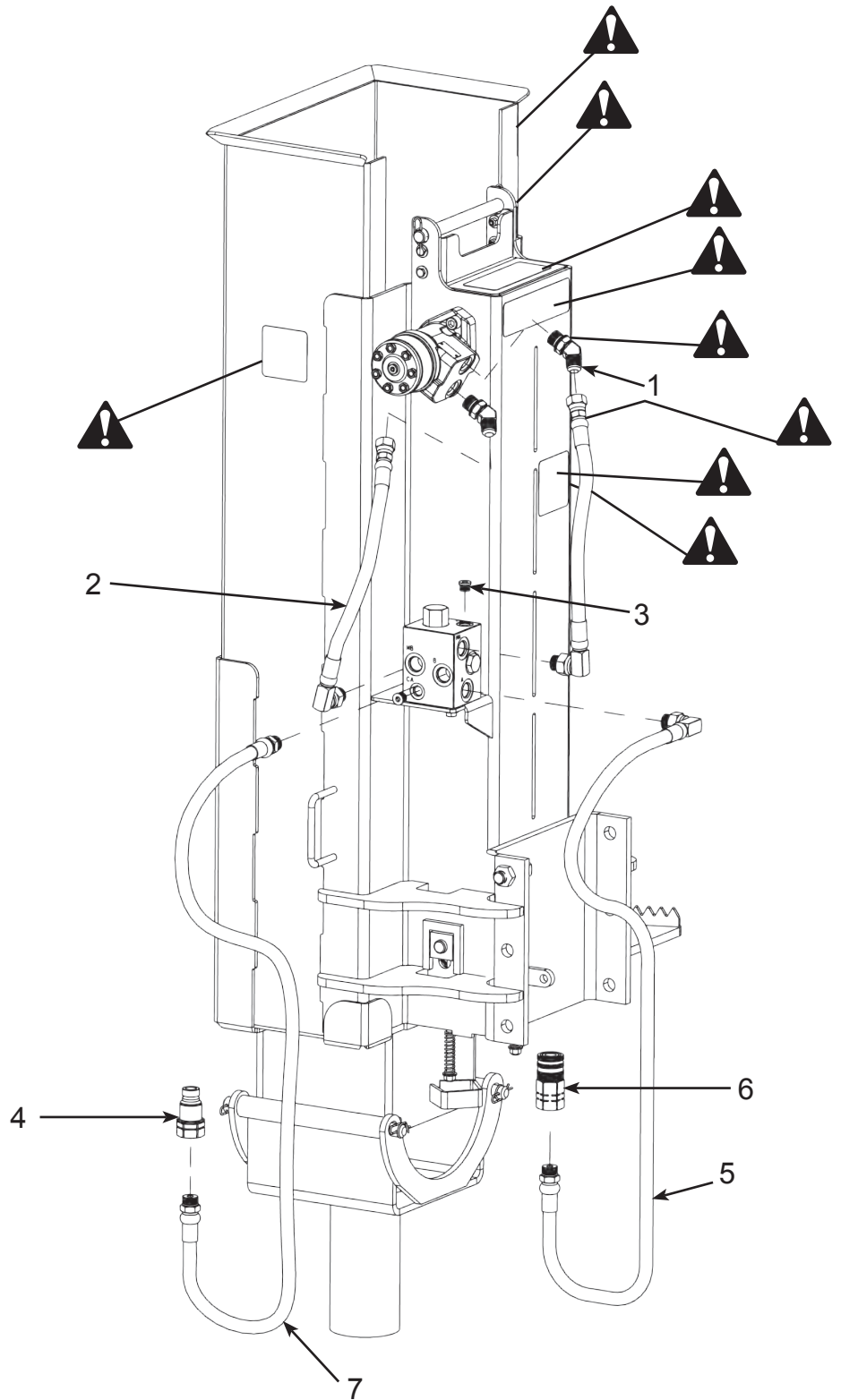

REF. NO.	PART NO.	DESCRIPTION	QTY.
1	10040	45° Elbow	2
2	21142	Motor-Manifold Hydraulic Hose	2
3	21141	#6 O-ring Plug	2
4	10048	Male Coupler	1
5	21155	Vehicle-Manifold Hydraulic Hose	1
6	10049	Female Coupler	1
7	21139	Vehicle-Manifold Hydraulic Hose	1

# Decals & Safety Signs



**PART NO. DIG21**  
Location: Unit, left side



**PART NO. DIG13**  
Location: Unit, left side



**PART NO. DANUSER101**  
Location: Unit, front



**PART NO. 9875**  
Location: Drive Unit, front

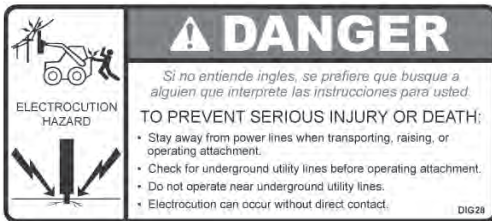

**PART NO. DIG28**  
Location: Unit, left side

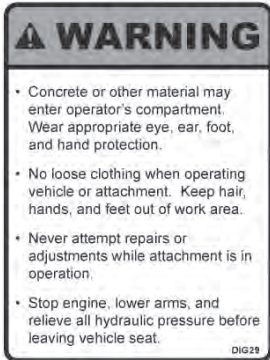

**PART NO. DIG29**  
Location: Unit, left side



**PART NO. DIG30**  
Location: Unit, left side

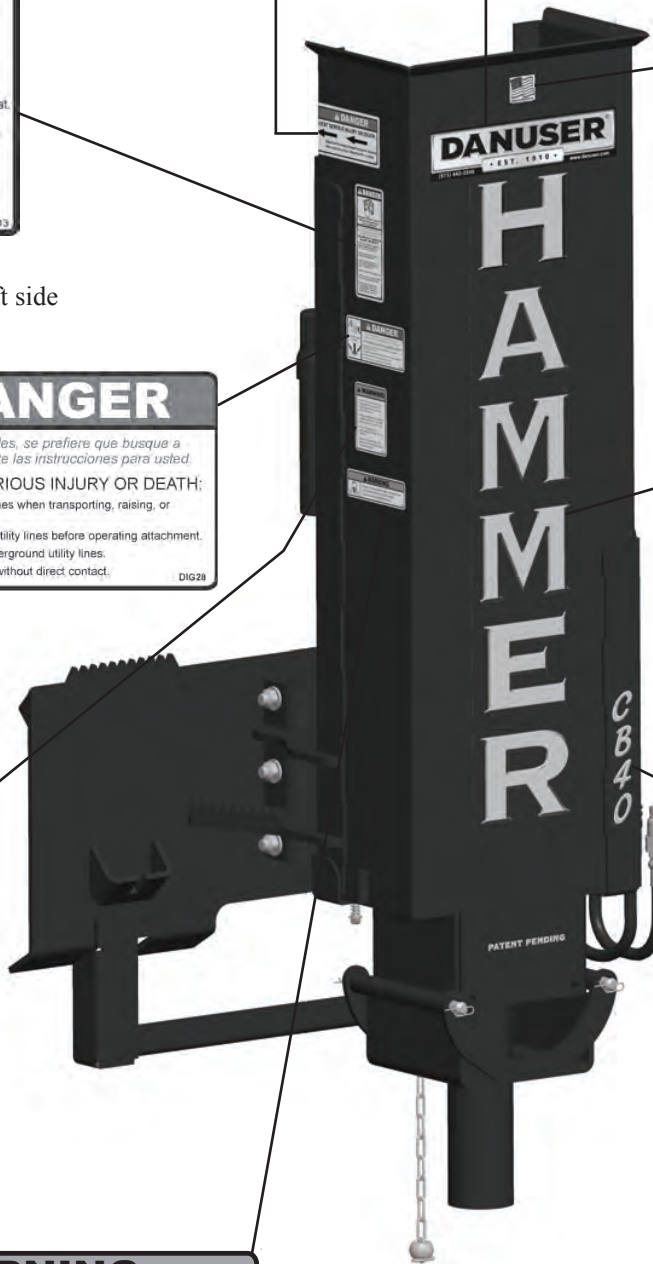

**HAMMER DECAL**  
Location: Unit, front



**CB40 DECAL**  
Location: Unit, front

## WARNING

Clean or replace all safety signs if they cannot be clearly read and understood.

# Decals & Safety Signs

(continued)



**PART NO. DIG22**  
 Location: Unit, rear shelf



**PART NO. DIG23**  
 Location: Unit, rear



**Model No. & Serial No.**  
 Location: Unit, rear



**PART NO. PHDC6**  
 Location: Unit, inside rear



**PART NO. DIG5**  
 Location:  
 Unit, right side



**PART NO. DIG24**  
 Location: Unit, rear



Clean or replace all safety signs if they cannot be clearly read and understood.

# Warranty

# DANUSER

Model # \_\_\_\_\_

## LIMITED WARRANTY

Serial # \_\_\_\_\_

Danuser LLC (“Danuser”) warrants its products, under normal use and maintenance, to be free from defects in material and workmanship for periods specified below from the purchase date from an authorized Danuser Dealer. Start of the warranty period is determined by purchase date given on your returned WARRANTY REGISTRATION FORM. Proof of purchase may be required. This Limited Warranty is extended only to the original purchaser of Danuser products.

Hammer - 1 Year

1. During the applicable warranty period, Danuser, at its option, will repair or replace any part determined by Danuser to be defective. Such repair or replacement shall take place at Danuser’s factory or a location designated by Danuser. Under no circumstances shall Danuser be obligated for the cost of any repair or replacement by anyone other than Danuser without its express written consent.
2. Parts may not be returned without written authorization from Danuser.
3. Some purchased components, including but not limited to hydraulic components are subject to the inspection and warranty of the respective manufacturer. Thus, delays in a warranty determination can be expected while Danuser awaits their decision.
4. This warranty is void if any attempt is made to make field repairs to hydraulic components. To qualify for warranty inspection, the “failed” part must be returned in its original “failed” condition.
5. To make a claim under this warranty, first contact your authorized Danuser Dealer. The Danuser Dealer shall complete the Warranty Claim Form and obtain written authorization from Danuser to return parts. All warranty claims must include detailed information regarding make and model of vehicle on which the Danuser product was mounted, hours of use, description of events that led up to the failure, and any other information helpful in reviewing the warranty claim. All warranty returns must be prepaid. Shipments arriving at our factory on a freight collect basis will be refused by our receiving department. The freight charge will be credited if the parts are determined by Danuser to be defective, and the associated freight costs in returning those parts will be prepaid by Danuser. **NOTE:** Hydraulic motors must arrive with all ports sealed from dirt and moisture. If a motor arrives with open ports, the warranty is void and no inspection will be made.
6. Products or parts thereof which, as determined by Danuser’s examination, show wear from normal use, have been improperly operated, damaged by accident or negligence, field repaired, altered or modified are not considered defective in material and workmanship and are not covered by this warranty. This warranty does not apply to parts subject to normal wear or to damage caused by the failure to perform recommended maintenance or to replace worn parts. This warranty shall not obligate Danuser to bear any cost of labor for field repair, replacement, testing, or adjustment nor for damage caused by accident, abuse, misuse, or environmental elements.
7. Any parts or labor required to repair or replace parts not covered under this warranty will be charged to the customer. Parts repaired or replaced by Danuser are then covered by this warranty only for the remainder of the original warranty as if such parts were original parts.
8. Danuser reserves the right to change its specifications and designs at any time.

This warranty is exclusive and in lieu of all other express warranties, if any, including the implied warranties of merchantability and fitness for a particular purpose. It shall not extend beyond the duration of the expressed warranty provided herein and the remedy for violations of any implied warranty shall be limited to repair or replacement of the defective part pursuant to the terms contained herein. No employee, dealer, salesman, or representative is authorized to change this warranty in any way or grant any other warranty. Danuser shall not be liable for any consequential, incidental, or punitive damages, losses, or expenses, including those resulting from or caused by any defects.

**Danuser LLC**  
**500 E. 3rd St.**  
**P.O. Box 368**  
**Fulton, MO 65251**

**Tel: (573) 642-2246**  
**Fax: (573) 642-2240**  
**E-mail: sales@danuser.com**  
**Website: www.danuser.com**