

HAMMER

SM40

Owner: _____

Date Purchased: _____

Model #: _____ Serial #: _____

Manual #: 9MHAM2456252

⚠ DANGER

Si no entiende ingles, se prefiere que busque a alguien que interprete las instrucciones para usted.

Operator's Manual

Danuser LLC
500 E. 3rd St.
P.O. Box 368
Fulton, MO 65251
Tel: (573) 642-2246 Fax: (573) 642-2240
E-mail: sales@danuser.com
Website: www.danuser.com



Dear Owner/Operator,

Thank you for purchasing this Danuser Hammer. We appreciate your business.

Your safety as an operator of our product is very important to us. Therefore, *before* you assemble, install, operate, maintain, service, remove, or move your Danuser Hammer, read and understand this manual thoroughly. If there is anything you do not understand, immediately contact your dealer, or contact our factory direct.

Phone:	(573) 642-2246
Fax:	(573) 642-2240
E-mail:	sales@danuser.com

Your satisfaction in the performance and longevity of our product is also very important to us and can be prolonged by proper assembly, installation, operation, maintenance, service, and removal as instructed in this manual.

Thank you again for your business and for your trust in our product. Please feel free to contact us at any time for further assistance.

Sincerely,

Danuser LLC

500 E. 3rd St., P.O. Box 368, Fulton, MO 65251
Tel: (573) 642-2246 Fax: (573) 642-2240
E-mail: sales@danuser.com Website: www.danuser.com

Foreword

Please read this manual thoroughly!

Before you assemble, install, operate, maintain, service, remove, or move your Danuser Hammer, read this manual thoroughly. If there is anything you do not understand, immediately contact your dealer, or call our factory direct at (573) 642-2246. Powered equipment can be dangerous if not assembled, installed, operated, maintained, serviced, removed, or moved properly.

Warranty Registration

To activate your warranty coverage and to provide you with efficient customer service, please fill out your WARRANTY REGISTRATION FORM. This form is included in your unit's paperwork package. If you did not complete a WARRANTY REGISTRATION FORM or did not receive one, please call Danuser LLC. Or, register online at www.Danuser.com. Your satisfaction with our product and your safety as a user of our product are both very important to us.

Symbols

 This SAFETY ALERT symbol identifies important safety messages. Carefully read each safety message that follows. Failure to understand and obey a safety message, or recognize a safety hazard, could result in injury or death to you or others around you. The operator is ultimately responsible for the safety of himself, as well as others, in the operating area of the Hammer.





<i>Symbol</i>	<i>Meaning</i>
	This is important information for proper use of this equipment. Failure to comply may lead to premature equipment failure.
	Failure to follow these instructions may cause damage to the implement or the vehicle, or minor personal injury.
	Failure to follow these instructions may result in personal injury or death.
	Immediate hazard! Failure to understand and obey this warning is likely to result in personal injury or death.

Table of Contents

	Page
Letter to the Owner/Operator	2
Foreword	3
Symbols	3
Safety	4
Specifications	6
Hydraulic Requirements	7
Assembly & Installation	8
Operation	11
Removal & Storage	14
Troubleshooting	15
Maintenance	16
Service	17
Parts	18
Decals & Safety Signs	26
Accessories	28
Warranty	Form No. 3269

Improper operation of this Hammer can cause serious personal injury or death. Operation of this Hammer should only be done by a competent adult acting in compliance with the Operator's Manual. Since Hammer operations are beyond our control, we disclaim all liability for any damages, injuries or death which may result.

WARNING

Working with unfamiliar equipment can lead to careless injuries. Read and understand this manual and the manual for your vehicle before assembling, installing, operating, maintaining, servicing, removing, or moving this Hammer. If there is anything in this manual you do not understand, contact your dealer or Danuser LLC. The safe use of this attachment is strictly up to you, the operator. If this attachment is used, loaned, or rented by any other person, it is the owner's responsibility to make certain that the operator prior to operating:

- Reads and understands the Operator's Manuals
- Is instructed in safe and proper use
- The Hammer is designed to be operated from the vehicle seat. Keep bystanders away from the work area. Do not operate with another person in contact with any part of the Hammer.
- All operators of this attachment must read and understand this entire manual, paying particular attention to safety messages and operation instructions, prior to assembling, installing, operating, maintaining, servicing, removing, or moving the Hammer.
- Please remember it is also important that you read, understand, and follow safety signs on the attachment. Clean or replace all safety signs if they cannot be clearly read and understood. They are there for your safety as well as the safety of others. Danuser LLC will furnish new safety signs upon request at no charge.
- All things with moving parts are potentially hazardous. There is no substitute for a cautious, safe-minded operator who recognizes potential hazards and follows reasonable safety practices.
- Personal protection equipment including hard hat, safety glasses, safety shoes, gloves, and ear plugs are recommended during assembly, installation, operation, maintenance, service, removal, or movement of the attachment.
- When the use of hand tools is required to perform any part of assembly, installation, operation, maintenance, or service of the attachment, be sure the tools used are designed and recommended by the tool manufacturer for that specific task.
- Never check pressurized system for leaks with your bare hand. Wear proper hand and eye protection and use wood or cardboard when searching for suspected leaks. Oil escaping from pinhole leaks under pressure can penetrate skin and create a serious medical emergency. If any fluid is injected into the skin, gangrene, blood poisoning, even death may result. Obtain medical attention immediately.
- Always use two people to handle heavy, unwieldy components during assembly, installation, maintenance, service, removal, or movement of the Hammer.
- Never place any part of your body where it would be in danger if movement should occur during assembly, installation, operation, maintenance, service, removal, or movement of the Hammer.
- Only properly trained people should operate this equipment. Do not allow anyone who has not read this entire manual and understands the safety rules, safety signs, and operation instructions to use this attachment.
- Never allow children to operate or be around the Hammer.
- Do not allow riders on the equipment at any time. There is no safe place for any riders.

Safety

(continued)

- Never use alcoholic beverages or drugs which can hinder alertness or coordination while operating this equipment. Consult your doctor about operating this equipment while taking prescription medications.
- Consult local utility companies to make certain there are no buried gas lines, electrical cables, etc., in the work area before beginning operation.
- Do not drive posts near underground utility lines.
- Stay away from power lines when transporting, raising, or operating the Hammer.
- Before you operate the attachment, check over pins and connections to be sure all are securely in place. Make sure the Hammer is securely latched to the vehicle.
- Keep hands, feet, hair, jewelry, and clothing away from all moving and/or rotating parts.
- Never place yourself between the vehicle and the attachment.
- Never allow anyone under the attachment at any time.
- Keep clear of the Hammer while in operation. Never position, align, or support the post by hand or with any tool when the Hammer is in operation.
- Do not exceed the vehicle's rated operating load. Use sufficient counterweights. Move the vehicle slowly when the attachment is raised.
- Carry the load low. A heavy load can cause instability of the vehicle. Use extreme care during travel. Slow down on turns and watch out for bumps. Use all safety devices, including a seat belt, as recommended in the vehicle operator's manual.
- Do not operate the Hammer on steep hillsides. When operating the Hammer on uneven or hilly terrain, position the vehicle with the attachment uphill. With the attachment downhill, the vehicle could tip when attempting to raise the attachment. Consult your vehicle operator's manual for maximum incline allowable.
- Always shut off the vehicle engine and remove the key before dismounting the vehicle, adjusting the attachment, or servicing the Hammer. Never leave equipment unattended with the vehicle running.
- Never attempt repairs or adjustments while the equipment is in operation.
- Before disconnecting hydraulic lines or fittings be sure to relieve all pressure by cycling all hydraulic controls after shutdown. Remember hydraulic systems are under pressure whenever the engine is running and may hold pressure after shutdown.
- Always use care when operating the Hammer. Most accidents occur because of neglect or carelessness.

Safety is a primary concern in the design, manufacture, sale, and use of Hammers. Danuser confirms to you, our customer, our concern for safety.

Specifications

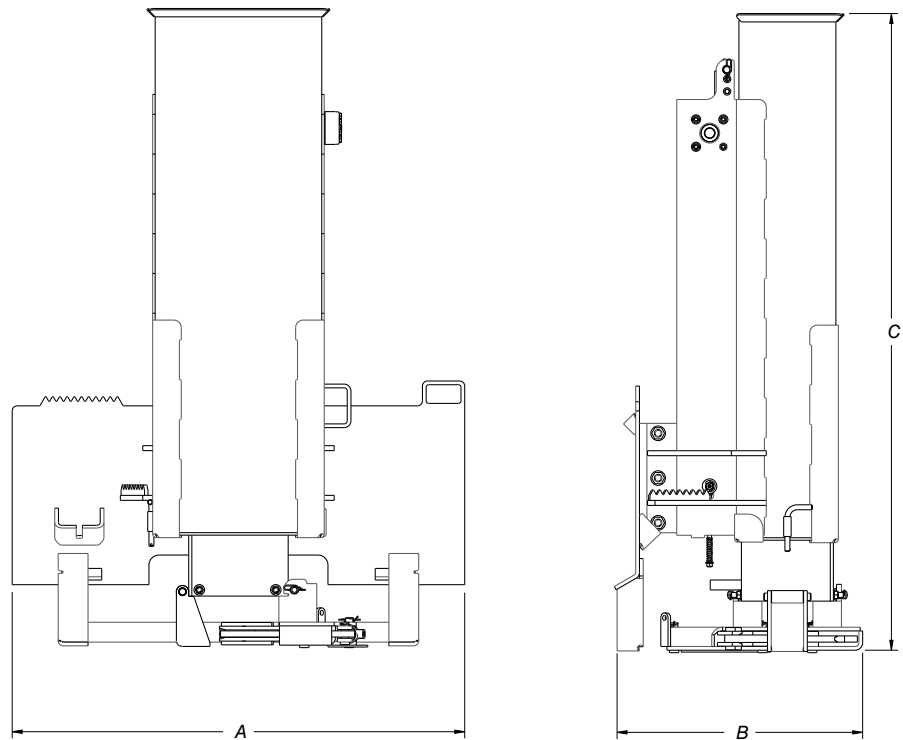

	Model SM40	Model SM40 w/ Grapple	Model SM40 w/ Tilt	Model SM40 w/ Tilt and Grapple
Overall Length (A)	45.5"			
Overall Width (B)	25"		25.5"	
Overall Height (C)	64"			
Tilt (left or right)	N/A		20°	
Hammer Weight	300 lbs. (500 lbs. max.)			
Length of Stroke	40"			
Max. Strokes Per Minute	35			
Hydraulic Requirements	1500-3000 PSI Up to 30 GPM			
Maximum Post Size	8.5" x 9.25"			
Impact Force	82000 lbs. @ 500 lb. weight			
Impact Energy	1025 ft.-lbs. @ 300 lb. weight; 1709 ft.-lbs. @ 500 lb. weight			

Hydraulic Requirements

Filtration Requirements:

- A filter of, at least, 25 micron filtration is required. A filter capable of 10 micron filtration is preferred. The majority of paper type filters are 25 microns or better.

NOTE

The life of the hydraulic motor is almost entirely dependent upon cleanliness of the oil. Instructions in your vehicle operator's manual regarding filter and oil changes should be carefully followed. Even small amounts of dirt in the hydraulic oil can cause premature motor failure that is not covered by warranty.

- A low pressure type filter can be installed in the return line from the control valves to the sump. A low pressure type filter can, also, be installed in the sump or pump intake line, but must be sized large enough to avoid starving the pump.
- A high pressure type filter can be used between the pump and the control valves.
- If the source of the hydraulic power does not have a filter, it will be necessary to install one at some point in the system so, at least, part of the hydraulic oil is being filtered whenever the system is operating. After a filter is installed and before attaching the Hammer, the entire hydraulic system should be drained, filled with new oil, and operated for 30 minutes or until the system is warm. During this run time, operate all valves, cylinders, and hydraulic motors on the attachment.

Pressure and Flow Requirements:

- The Hammer is designed to operate up to 30 GPM and 1500 – 3000 PSI.

Valve Requirements:

- The hydraulic system used to power the Hammer should be equipped with a four-way valve large enough to carry full pump outlet without restricting flow and causing oil heating.
- The four-way valve requires a relief valve which will open and relieve extreme pressures between the Hammer and control valve, even when the control valve is in a neutral position. This feature can be obtained by connecting two external relief valves between the main lines running from the control valve to the Hammer in such a way that high pressure in either line will be relieved to the other line.

Hydraulic Fluid Selection Requirements:

- Premium grade petroleum based fluids will provide the best performance.
- Fluids that contain anti-wear agents, rust inhibitors, anti-foaming agents, and oxidation inhibitors are recommended.
- The viscosity of the fluid should never fall below 70 SUS (13 cST). The best viscosity range of the Hammer is 100-200 SUS (20-43 cST).

Assembly & Installation

WARNING

Personal protection equipment including hard hat, safety glasses, safety shoes, gloves, and ear plugs are recommended during assembly, installation, operation, maintenance, service, removal, or movement of the attachment.

CAUTION

Because of the weight of some components, and because some components are difficult to balance, two people are required for safe assembly and installation of this equipment.

Add Additional Weight

For tough driving conditions or large posts, additional weight can be added up to 500 lbs. total hammer weight by purchasing a weight kit or by adding weight. Add weight in a variety of ways: logging chain, metal punch slugs, lead tire weights, etc. Do not use concrete or sand, as damage may result.

- STEP 1: Make sure the hammer weight catch is visible through the viewing slots on the back of the case.
- STEP 2: Remove the retention pin from the top of the case. Insert a hook into the lifting eye located on the top of the weight. Lift the weight out of the Hammer with a hoist, forklift, or another vehicle. Set the weight on the ground.
- STEP 3: Remove the weight cover by loosening the two lock nuts. It may be necessary to use a hammer and punch in order to break the weight cover loose.
- STEP 4: Place the additional weight into the cavity of the hammer weight until full.
- STEP 5: Reinstall the weight cover using the two washers and lock nuts, making sure to seal the cover with silicone sealant.
- STEP 6: Lower the weight back into the Hammer and reinstall the retention pin.

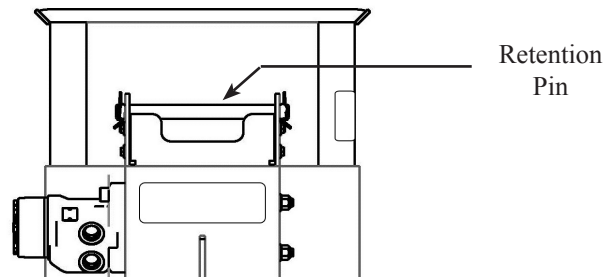

WARNING

Do not tilt or operate the Hammer without the retention pin in place. The hammer weight could slide out of the Hammer and cause serious injury or death.

Prepare the Vehicle

Read and understand the manual for your vehicle before assembling or installing the Hammer. The vehicle must be equipped with a universal quick attach hitch and auxiliary hydraulics. The use of the Hammer may require the addition of counterweights to ensure the attachment does not exceed the rated capacity of the vehicle.

DANGER

Do not exceed the vehicle's rated operating load. If necessary, use sufficient counterweights.

- STEP 1: Install the Hammer by following your vehicle operator's manual for installing an attachment.

WARNING

Make sure the Hammer is securely latched to the vehicle. Failure to do so could result in separation of the attachment from the vehicle.

Assembly & Installation

(continued)

STEP 2: Raise the Hammer slightly, and latch the parking stand into the upright position.

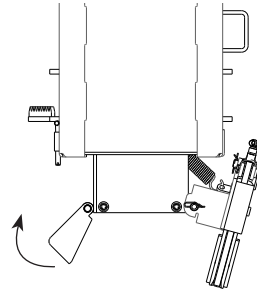

STEP 3: Route the hydraulic hoses through the quick attach plate hose holder, and connect the hydraulic hoses to the vehicle's auxiliary hydraulics.

! WARNING

Remember hydraulic systems are under pressure whenever the engine is running and may hold pressure after shutdown. Before connecting or disconnecting hydraulic hoses, be sure to relieve all pressure by cycling all hydraulic controls after shutdown.

STEP 4: Ensure the retention pin is in place. The retention pin prevents the hammer weight from sliding out of the Hammer.

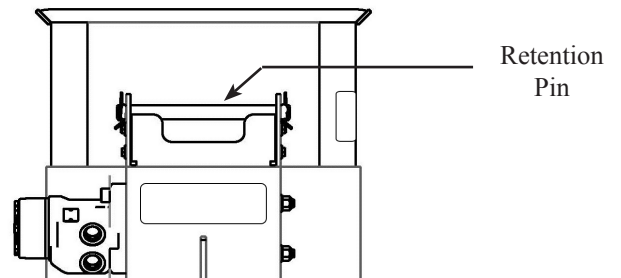

! WARNING

Do not tilt or operate the Hammer without the retention pin in place. The hammer weight could slide out of the Hammer and cause serious injury or death.

STEP 5: Shut off the vehicle engine.

STEP 6: Oil the Hammer drive chain, and grease all zerks.

STEP 7: Start the vehicle. Engage the auxiliary hydraulics. Note the direction of the chain rotation (visible from the operator's seat). The hammer weight catch should be rotating from the top to the bottom. If the chain is not rotating at all, reverse the hydraulic hoses.

! WARNING

Remember hydraulic systems are under pressure whenever the engine is running and may hold pressure after shutdown. Before connecting or disconnecting hydraulic hoses, be sure to relieve all pressure by cycling all hydraulic controls after shutdown.

Assembly & Installation

(continued)

STEP 8: Check the hydraulic system for leaks.

WARNING

Never check pressurized system for leaks with your bare hand. Wear proper hand and eye protection and use wood or cardboard when searching for suspected leaks. Oil escaping from pinhole leaks under pressure can penetrate skin and create a serious medical emergency. If any fluid is injected into the skin, gangrene, blood poisoning, even death may result. Obtain medical attention immediately.

Tilt Option

If the Hammer is equipped with Tilt, follow the instructions below.

STEP 9: Grease the grease zerk on the tilt pivot boss.

STEP 10: Route the wires along the hydraulic hoses to the vehicle, and secure them with zip-ties.

STEP 11: Route the control portion of the wiring harness along the loader arm of the vehicle and into the cab, and secure the wiring with zip-ties. Mount the switch out of the way of other controls.

NOTE

Keep wiring a safe distance from hot components such as a heater or exhaust.

STEP 12: Connect the remainder of the wiring harness to a 12 volt power supply. If necessary, consult your dealer.

Operation

SM40

DANGER

The Hammer is designed to be operated from the vehicle seat. Keep bystanders away from the work area. Do not operate with another person in contact with any part of the Hammer.

DANGER

Stay away from power lines when transporting, raising, or operating the attachment.

WARNING

Personal protection equipment including hard hat, safety glasses, safety shoes, gloves, and ear plugs are recommended during assembly, installation, operation, maintenance, service, removal, or movement of the attachment.

DANGER

Before you operate the attachment, check over pins and connections to be sure they all are securely in place. Make sure the Hammer is securely latched to the vehicle.

DANGER

Consult local utility companies to make certain there are no buried gas lines, electrical cables, etc., in the work area before beginning operation. Do not drive posts near underground utility lines.

STEP 1: Without the Grapple, the Hammer requires a second person to position the post. This person will set the post at the desired location and grasp the post securely, making sure his hands are at least 30 inches (30") from the top of the post.

DANGER

When using a second person, do not turn on the auxiliary hydraulics until the second person is clear from the work area.

STEP 2: After the post is in position, move the vehicle with the arms raised, and position the Hammer directly over the top of the post.

STEP 3: Lower the Hammer onto the top of the post, ensuring the post is inside of the lower portion of the Hammer. Continue lowering the Hammer until the floating anvil has moved up and the weight of the Hammer is supported by the post.

DANGER

After the post is in position, the second person must move away from the Hammer and vehicle.

STEP 4: After the second person has cleared the area, place the loader arms in the float position. If the vehicle is not equipped with float, the loader arms should be lowered, applying down force to the post.

STEP 5: Move the vehicle slowly left, right, forward, or backward as needed until the post appears vertical to the ground.

STEP 6: The Hammer can now be activated by turning the auxiliary hydraulics to the forward position. If you are not using the loader float position, the loader arms should be lowered as the post is driven into the ground.

STEP 7: Drive the post to the desired depth.

STEP 8: As soon as the weight is released (starts to drop), shut off the auxiliary hydraulics, raise the Hammer until the post is cleared, and move to the next post.

NOTE

When stopping the Hammer, the hammer weight catch should be visible through the viewing slots on the back of the case. Never stop the Hammer with the hammer weight partially raised.

Operation

SM40 w/ Grapple

DANGER

The Hammer is designed to be operated from the vehicle seat. Keep bystanders away from the work area. Do not operate with another person in contact with any part of the Hammer.

DANGER

Stay away from power lines when transporting, raising, or operating the attachment.

WARNING

Personal protection equipment including hard hat, safety glasses, safety shoes, gloves, and ear plugs are recommended during assembly, installation, operation, maintenance, service, removal, or movement of the attachment.

DANGER

Before you operate the attachment, check over pins and connections to be sure they all are securely in place. Make sure the Hammer is securely latched to the vehicle.

DANGER

Consult local utility companies to make certain there are no buried gas lines, electrical cables, etc., in the work area before beginning operation. Do not drive posts near underground utility lines.

- STEP 1: Raise the Hammer approximately two feet (2') off the ground with the Hammer tilted slightly forward so the grapple jaws are visible.
- STEP 2: Drive the vehicle forward and position the grapple jaws around the post, approximately four inches (4") from the top of the post.
- STEP 3: Activate the auxiliary hydraulics in the reverse direction for two (2) seconds or until the grapple jaws are firmly clamped around post.
- STEP 4: Raise the loader arms until the bottom of the post is above the ground.
- STEP 5: Position the post in desired location and lower the Hammer until the post is inside the lower portion of the Hammer.
- STEP 6: Intermittently activate auxiliary hydraulics in the forward direction to release the grapple jaws from the post. The Grapple will rotate up and away from the post.
- STEP 7: Continue lowering the Hammer until the floating anvil has moved up and the weight of the Hammer is supported by the post.
- STEP 8: Place the loader arms in the float position. If the vehicle is not equipped with float, the loader arms should be lowered, applying down force to the post.
- STEP 9: Move the vehicle slowly left, right, forward, or backward as needed until the post appears vertical to the ground.
- STEP 10 : The Hammer can now be activated by turning the auxiliary hydraulics to the forward position. If you are not using the loader float position, the loader arms should be lowered as the post is driven into the ground.
- STEP 11: Drive the post to the desired depth.
- STEP 12: As soon as the weight is released (starts to drop), shut off the auxiliary hydraulics, raise the Hammer until the post is cleared, and move to the next post.

NOTE

When stopping the Hammer, the hammer weight catch should be visible through the viewing slots on the back of the case. Never stop the Hammer with the hammer weight partially raised.

Operation

SM40 w/ Tilt and Grapple

! DANGER

The Hammer is designed to be operated from the vehicle seat. Keep bystanders away from the work area. Do not operate with another person in contact with any part of the Hammer.

! DANGER

Stay away from power lines when transporting, raising, or operating the attachment.

! WARNING

Personal protection equipment including hard hat, safety glasses, safety shoes, gloves, and ear plugs are recommended during assembly, installation, operation, maintenance, service, removal, or movement of the attachment.

! DANGER

Before you operate the attachment, check over pins and connections to be sure they all are securely in place. Make sure the Hammer is securely latched to the vehicle.

! DANGER

Consult local utility companies to make certain there are no buried gas lines, electrical cables, etc., in the work area before beginning operation. Do not drive posts near underground utility lines.

STEP 1: Remove the tilt lock pin.

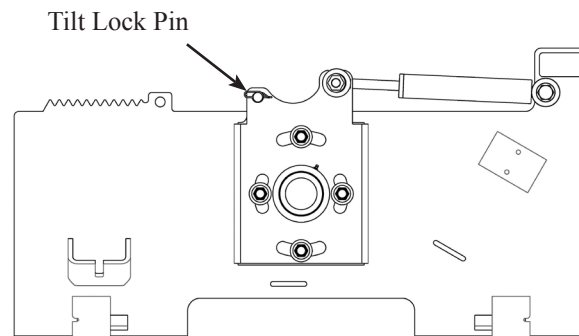

STEP 2: Raise the Hammer approximately two feet (2') off the ground with the Hammer tilted slightly forward so the grapple jaws are visible.

STEP 3: Drive the vehicle forward and position the grapple jaws around the post, approximately four inches (4") from the top of the post.

STEP 4: Activate the auxiliary hydraulics in the reverse direction for two (2) seconds or until the grapple jaws are firmly clamped around post.

STEP 5: Raise the loader arms until the bottom of the post is above the ground.

STEP 6: Position the post in desired location and lower the Hammer until the post is inside the lower portion of the Hammer.

STEP 7: Intermittently activate auxiliary hydraulics in the forward direction to release the grapple jaws from the post. The Grapple will rotate up and away from the post.

STEP 8: Continue lowering the Hammer until the floating anvil has moved up and the weight of the Hammer is supported by the post.

STEP 9: Place the loader arms in the float position. If the vehicle is not equipped with float, the loader arms should be lowered, applying down force to the post.

STEP 10: Move the vehicle slowly left, right, forward, or backward as needed until the post appears vertical to the ground.

STEP 11: Activate the electrical control switch.

STEP 12: Tilt the Hammer to a vertical position. Activate the auxiliary hydraulics to tilt the Hammer clockwise up to 20 degrees (20°). Activating the auxiliary hydraulics in reverse will tilt the Hammer counter-clockwise up to 20 degrees (20°).

Operation

(continued)

Removal & Storage

WARNING

Personal protection equipment including hard hat, safety glasses, safety shoes, gloves, and ear plugs are recommended during assembly, installation, operation, maintenance, service, removal, or movement of the attachment.

STEP 13: Deactivate the electrical control switch.

STEP 14: The Hammer can now be activated by turning the auxiliary hydraulics to the forward position. If you are not using the loader float position, the loader arms should be lowered as the post is driven into the ground.

STEP 15: Drive the post to the desired depth.

STEP 16: As soon as the weight is released (starts to drop), shut off the auxiliary hydraulics, raise the Hammer until the post is cleared, and move to the next post.

NOTE

When stopping the Hammer, the hammer weight catch should be visible through the viewing slots on the back of the case. Never stop the Hammer with the hammer weight partially raised.

DANGER

Before disconnecting the Hammer from the vehicle, tilt to a vertical position and reinstall the tilt lock pin. Failure to do so will cause the Hammer to become unstable in the free-standing position.

Before storage, the Hammer should be thoroughly cleaned, washing off all dirt and grime. If you have a Grapple or Tilt, coat the exposed portions of the cylinder rod with grease. Lubricate the drive chain, and grease all zerks. Make sure the hydraulic system is properly sealed against contaminants entering the unit. Always store the Hammer in a dry, covered location.

STEP 1: Lower the parking stand by pulling up on the lock pin.

STEP 2: Lower the Hammer onto a flat, level surface. If the Hammer is equipped with a Grapple, lower the Hammer until the end of the Grapple jaws touch the ground. Shift the vehicle to the left while lowering the Hammer in order to rotate the Grapple to the horizontal position.

NOTE

Always store the Hammer with the Grapple horizontal.

DANGER

Never allow anyone under the attachment at any time.

STEP 3: Shut off the vehicle engine, lower the arms, relieve all hydraulic pressure (by activating the vehicle controls), and remove the vehicle key before leaving the vehicle seat.

WARNING

Before disconnecting hydraulic lines or fittings be sure to relieve all pressure by cycling all hydraulic controls after shutdown. Remember hydraulic systems are under pressure whenever the engine is running and may hold pressure after shutdown.

STEP 4: Disconnect the hydraulic hoses from the vehicle's auxiliary hydraulics.

NOTE

Connect the quick couplers together to prevent contaminants from entering the Hammer hydraulic system.

STEP 5: Follow your vehicle operator's manual for removing an attachment.

Troubleshooting

PROBLEM	POSSIBLE CAUSE	SOLUTION
Floating anvil falls out or gets jammed	<ul style="list-style-type: none"> a. Weight is not down after driving b. Post too small 	<p>When finished driving, make sure weight is down and/or catch is visible through viewing slots. Refer to Operation section of manual.</p> <p>Use T-post adapter when driving small posts.</p>
Weight is dropping unexpectedly	<ul style="list-style-type: none"> a. Weight is not down after driving 	<p>When finished driving, make sure weight is down and/or catch is visible through viewing slots. Refer to Operation section of manual.</p>
Vehicle battery is dead	<ul style="list-style-type: none"> a. Tilt switch was activated too long 	<p>Deactivate tilt switch when Hammer is not in use.</p>
Weight not cycling	<ul style="list-style-type: none"> a. No post loaded in Hammer b. Broken or missing shaft key c. Channel is not lubricated d. Motor damaged 	<p>A post must be pushed up inside the Hammer until it stops before the weight will cycle.</p> <p>Replace key.</p> <p>Grease the inside of the Hammer case.</p> <p>Contact Danuser.</p>
Motor will not operate	<ul style="list-style-type: none"> a. Motor damaged b. Incorrect hose routing 	<p>Contact Danuser.</p> <p>Refer to Hydraulics section of manual for proper hose routing.</p>
Chain jumps	<ul style="list-style-type: none"> a. Incorrect chain tension b. Sprockets or chain are worn 	<p>Adjust chain tension.</p> <p>Replace worn item(s).</p>
Oil over heating	<ul style="list-style-type: none"> a. High flow activated b. Low oil level c. Dirty oil or oil filter 	<p>Ensure vehicle is not in high flow mode.</p> <p>Fill reservoir to proper level.</p> <p>Change oil and filter.</p>
Tilt feature not working	<ul style="list-style-type: none"> a. No power to solenoid b. Blown fuse c. Solenoid not working d. Tilt lock pin in place 	<p>Check electrical connections. Ensure switch is activated.</p> <p>Check inline fuse in electrical harness. Check vehicle's fuses.</p> <p>Contact Danuser.</p> <p>Remove tilt lock pin. Refer to Operation section of manual.</p>
Tilt or grapple cylinder not working	<ul style="list-style-type: none"> a. Air in hydraulic system b. Incorrect hose routing c. Tilt or Grapple obstruction d. Cylinder damaged 	<p>Cycle hydraulics until both cylinders have completely extended and retracted (fully cycled).</p> <p>Refer to Hydraulics section of manual for proper hose routing.</p> <p>Ensure tilt and grapple mechanisms can move freely.</p> <p>Contact Danuser.</p>

For additional assistance, please call your dealer or contact Danuser direct:

Phone: (573) 642-2246

Fax: (573) 642-2240

E-mail: sales@danuser.com

WARNING

Personal protection equipment including hard hat, safety glasses, safety shoes, gloves, and ear plugs are recommended during assembly, installation, operation, maintenance, service, removal, or movement of the attachment.

DAILY

CHECK FOR CLEAN HYDRAULIC OIL

The majority of all hydraulic component failures are caused by contamination of the hydraulic oil. At all times, keep dirt and other contaminants from entering the hydraulic system during connecting and disconnecting the hydraulic system. Always use dust caps and plugs on all quick disconnects when not in use.

CHECK ALL HYDRAULIC HOSE ASSEMBLIES

Check for cracked or brittle hoses. Replace hoses immediately if cracked or brittle. Replacement of hoses before failure will prevent loss of hydraulic oil, hydraulic oil contamination, and component damage caused by cavitation.

CHECK ATTACHMENT AND ALL ACCESSORIES

Check all bolts and fasteners for tightness. Visually inspect the attachment for damage.

EVERY 40 HOURS

GREASE ZERKS

Grease the zerk on the drive chain bearing. Grease the zerk on the bottom chain sprocket shaft. If equipped with Tilt, grease the zerk on the tilt pivot boss.

LUBRICATE ATTACHMENT

Grease the inside of the Hammer case. Lubricate the drive chain with a high quality commercial grade chain lubricant.

CHECK ATTACHMENT AND ACCESSORIES

Visually inspect all welds for cracks. Check the chain catch for wear. Check all bolts and fasteners for tightness.

CHECK CHAIN TENSION

Inspect the chain tensioning springs. Springs should be preloaded but not entirely collapsed.

WARNING

Personal protection equipment including hard hat, safety glasses, safety shoes, gloves, and ear plugs are recommended during assembly, installation, operation, maintenance, service, removal, or movement of the attachment.

CAUTION

Because of the weight of some components, and because some components are difficult to balance, two people are required for servicing of this equipment.

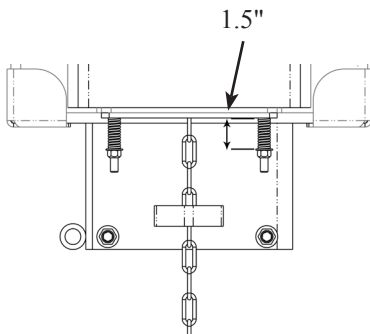

Tighten tensioning nuts until springs are adequately preloaded

DANGER

Never attempt repairs or adjustments while the equipment is in operation.

Replacing the Drive Chain

- STEP 1: Make sure the hammer weight catch is visible through the viewing slots on the back of the case.
- STEP 2: Remove the retention pin from the top of the case. Insert a hook into the lifting eye located on the top of the weight. Lift the weight out of the Hammer with a hoist, forklift, or another vehicle. Set the weight on the ground.
- STEP 3: Carefully lay down the Hammer on its front side.
- STEP 4: Remove the top and bottom chain covers.
- STEP 5: Remove the retaining ring fastened to the lower sprocket shaft assembly, and pull out the shaft from the opposite side of the Hammer.
- STEP 6: Remove the tensioning rods and shim(s). Slide chain slack to the top of the Hammer.
- STEP 7: Find the chain catch and two pins that secure it. Remove the clips that retain the pins, and remove the pins.
- STEP 8: Install new chains over the upper sprocket shaft assembly. Make sure open ends of the chain are at equal links away from sprockets.
- STEP 9: Reinstall the chain catch and pins through the open ends of the new chain. Install clips on the pins.
- STEP 10: Slide chain slack to the bottom of the Hammer, and insert the lower sprocket shaft assembly into the chain.

NOTE

Shim(s) must be inserted between the tensioning rods and the lower sprocket shaft assembly to maintain proper sprocket location.

- STEP 11: Insert the lower sprocket shaft through the side of the Hammer and through the tensioning rods and sprockets.
- STEP 12: Install shim(s) and retaining ring on the end of the sprocket shaft.
- STEP 13: Install bottom chain guard and tensioning springs. Tighten tensioning nuts until the springs are adequately preloaded but not entirely collapsed.
- STEP 14: Install the top chain cover, stand Hammer upright, reinstall weight, and install the retention pin.

WARNING

Do not tilt or operate the Hammer without the retention pin in place. The hammer weight could slide out of the Hammer and cause serious injury or death.

Parts

 = Safety Sign Location

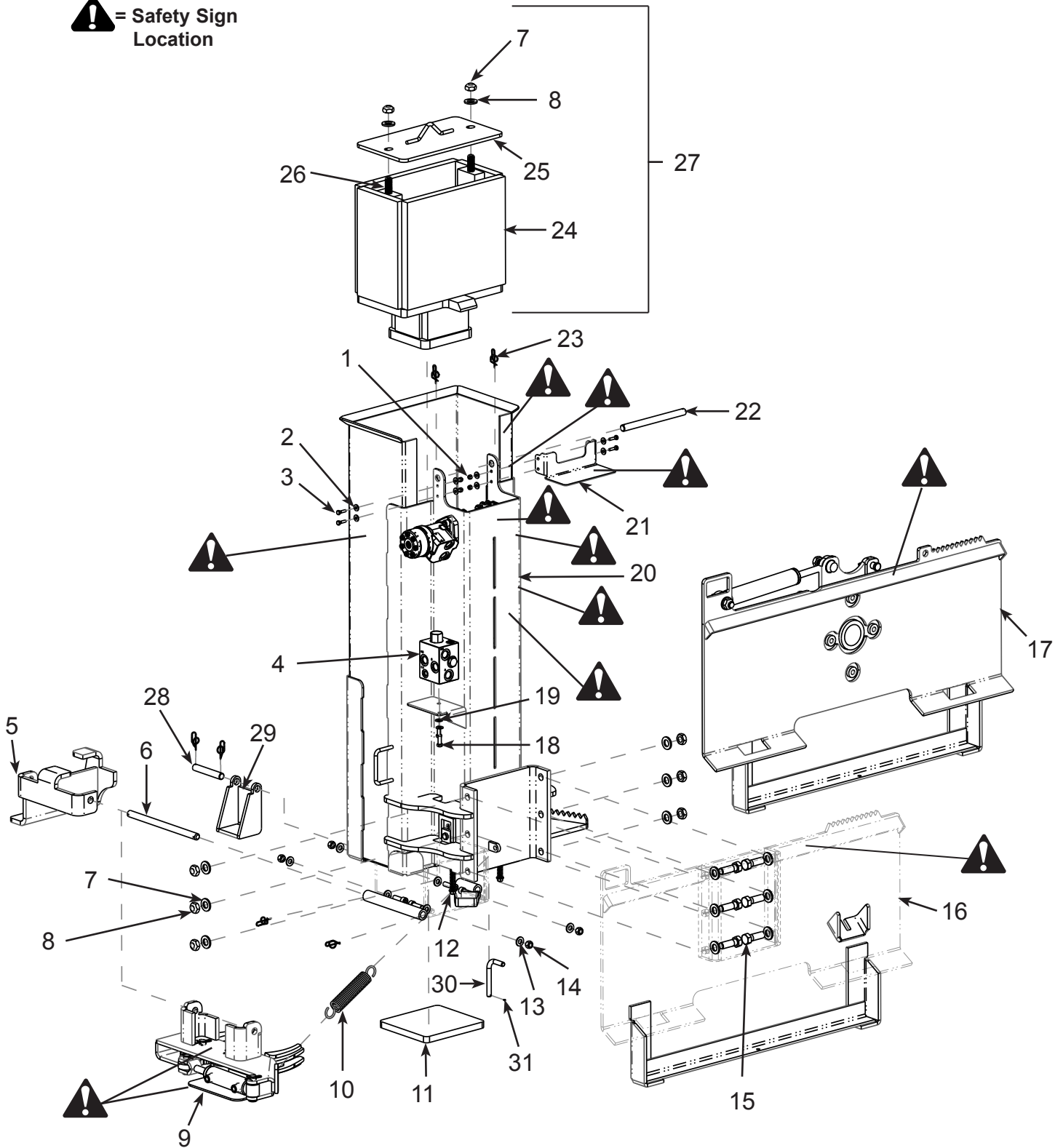

Parts

(continued)

REF. NO.	PART NO.	DESCRIPTION	QTY.
1	10195	Toplock Nut (1/4"-20)	4
2	21056	1/4" Flat Washer	4
3	21055	Bolt (1/4"-20 x 1")	4
4	21137	Hydraulic Manifold	1
5	21169	Foot	1
6	21079	Pin	1
7	10268	3/4" Flat Washer	8
8	10267	Toplock Nut (3/4"-10)	8
9	21062	Grapple Assembly	1
10	21148	Grapple Spring	1
11	21124	Floating Anvil	1
12	6156	Socket Head Bolt (1/2"-13 x 1-1/2")	4
13	21156	1/2" Flat Washer	8
14	10125	Toplock Nut (1/2"-13)	4
15	21105	Bolt (3/4"-10 x 2-1/4" Gr. 5)	6
16	21086	Quick Attach Plate	1
17	21093	Quick Attach Plate w/ Tilt	1
18	21157	Bolt (3/8"-16 x 1")	2
19	2178	3/8" Flat Washer	2
20	21026	Case	1
21	21133	Cover	1
22	21118	Retention Pin	1
23	21078	Rue Clip	6
24	21045	Weight	1
25	21051	Cover	1
26	21054	Stud (3/4"-10 x 3-1/4")	2
27	21044	Weight Assembly (consists of items 7, 8, 24, 25, and 26)	1
28	21207	Pin	1
29	21208	Parking Stand	1
30	21206	Pin	1
31	2164	Drive Screw	1

Parts

Drive Assembly

 = Safety Sign Location

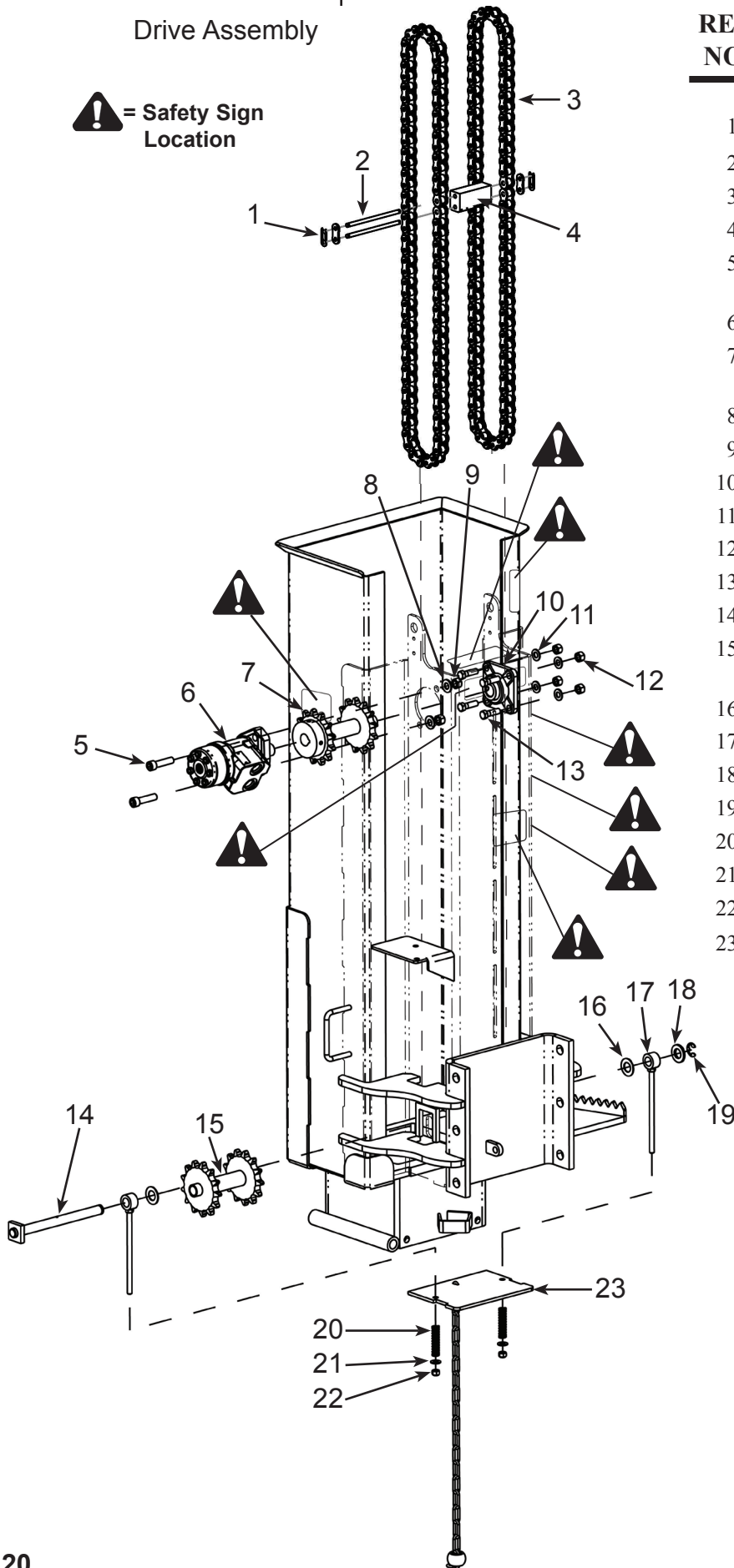

REF. NO.	PART NO.	DESCRIPTION	QTY.
1	21119	Connecting Link	2
2	21024	Chain Pin	2
3	21025	Roller Chain #80, 1" Pitch	2
4	21122	Catch Weight	1
5	21126	Socket Head Bolt (1/2"-13 x 2")	2
6	21113	Hydraulic Motor	1
7	21114	Upper Sprocket Shaft Assembly	1
8	21156	1/2" Flat Washer	2
9	10125	Toplock Nut (1/2"-13)	2
10	21043	Bearing	1
11	2489	7/16" Flat Washer	4
12	10197	Toplock Nut (7/16"-14)	4
13	21057	Bolt (7/16"-14 x 1-1/2")	4
14	21040	Sprocket Shaft	1
15	21080	Lower Sprocket Shaft Assembly	1
16	21125	Shim	2
17	21083	Tensioning Rod	2
18	10267	3/4" Flat Washer	1
19	2172	Retaining Ring	1
20	21123	Spring	2
21	2178	3/8" Flat Washer	2
22	10412	Toplock Nut (3/8"-16)	2
23	21110	Cover Assembly	1

Parts

Hydraulics

 = Safety Sign Location

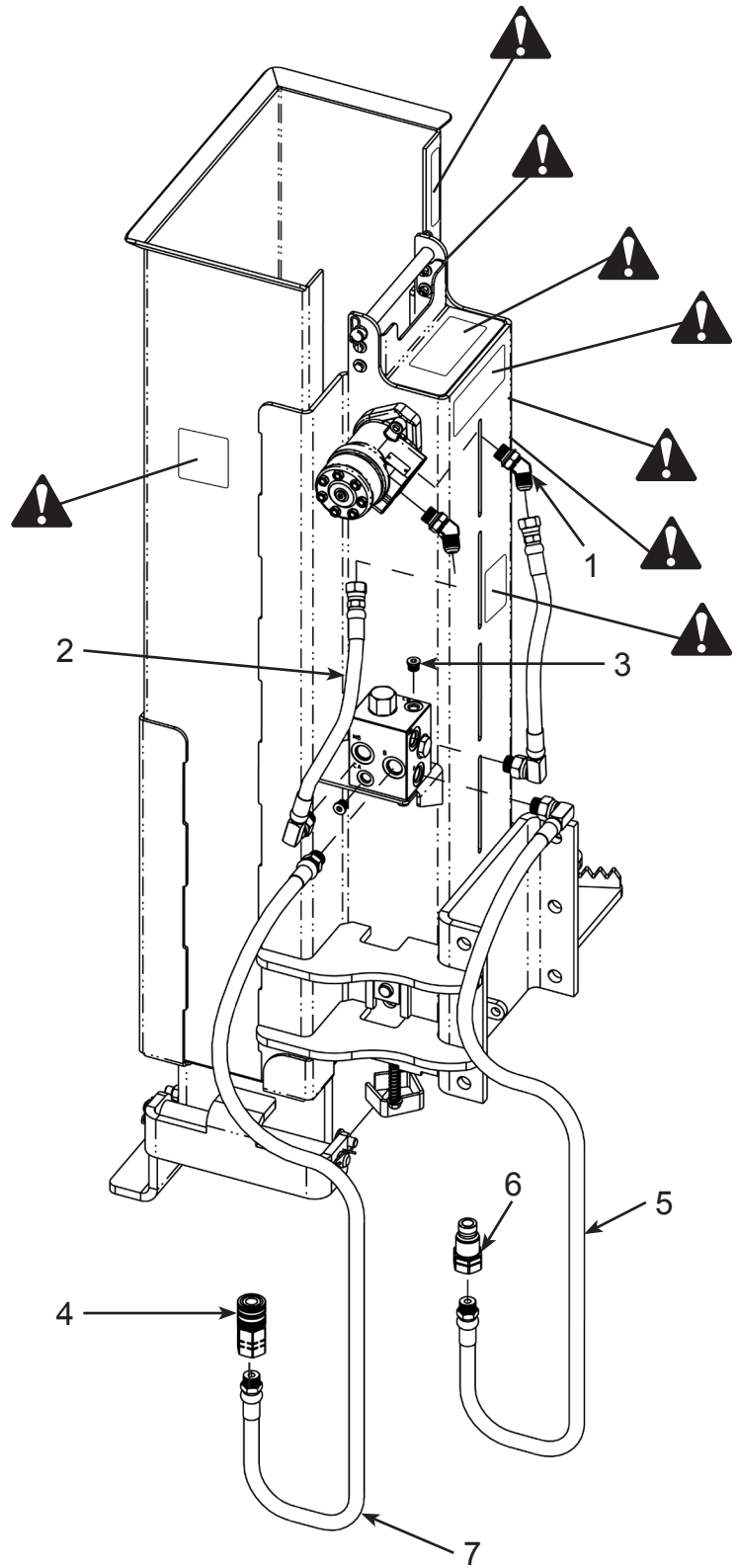

REF. NO.	PART NO.	DESCRIPTION	QTY.
1	10040	45° Elbow	2
2	21142	Motor-Manifold Hydraulic Hose	2
3	21141	#6 O-ring Plug	2
4	10049	Female Coupler	1
5	21155	Vehicle-Manifold Hydraulic Hose	1
6	10048	Male Coupler	1
7	21139	Vehicle-Manifold Hydraulic Hose	1

Parts

Tilt Hydraulics

 = Safety Sign Location

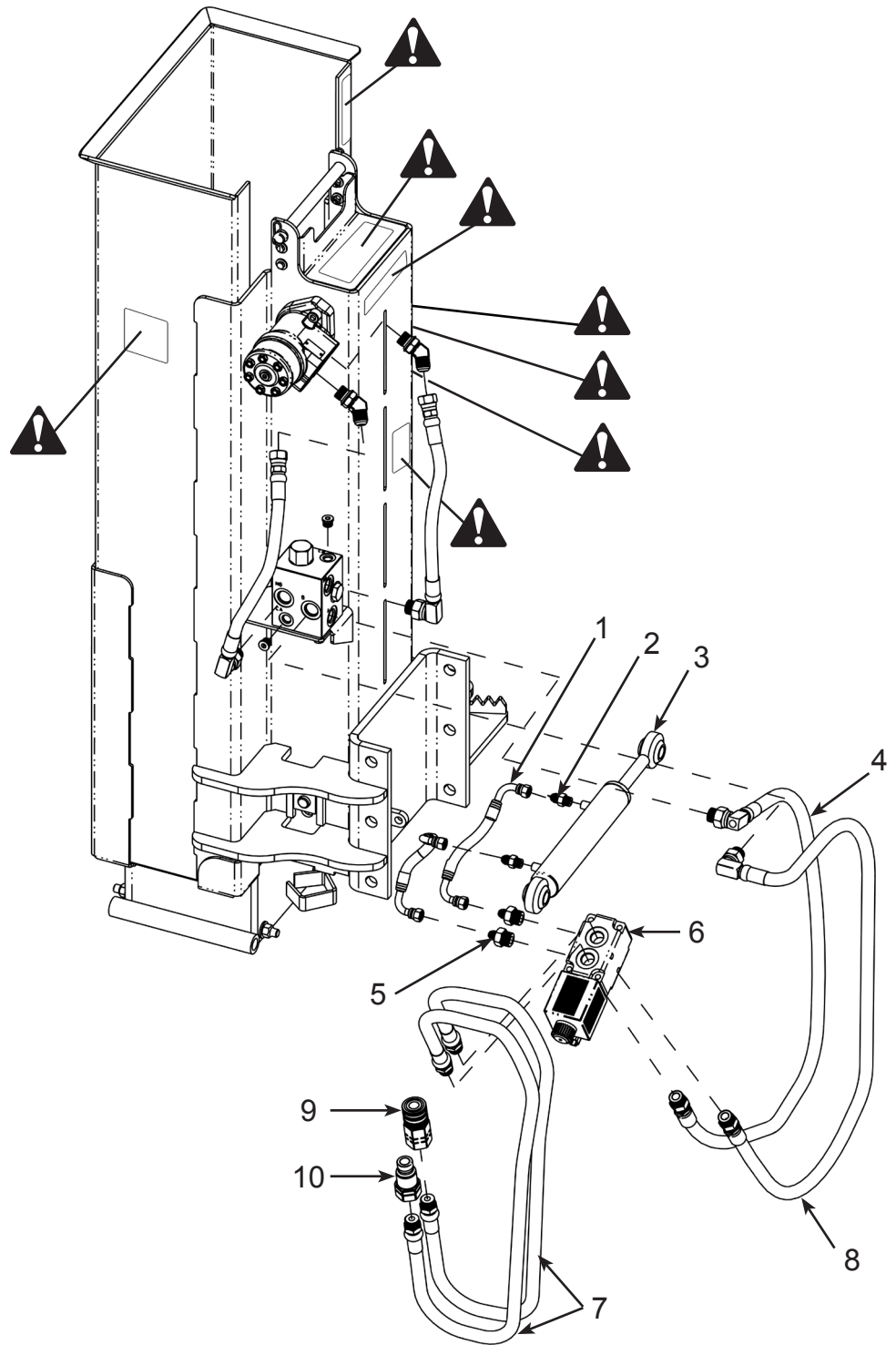

REF. NO.	PART NO.	DESCRIPTION	QTY.
1	21164	Diverter-Cylinder Hydraulic Hose	2
2	21154	Restrictor	2
3	21103	Hydraulic Cylinder	1
4	21147	Diverter-Manifold Hydraulic Hose	1
5	21153	#10 O-ring #6 JIC Fitting	2
6	21128	Diverter Valve	1
7	21145	Vehicle-Diverter Hydraulic Hose	2
8	21146	Diverter-Cylinder Hydraulic Hose	1
9	10049	Female Coupler	1
10	10048	Male Coupler	1

Parts

Grapple Hydraulics

 = Safety Sign Location

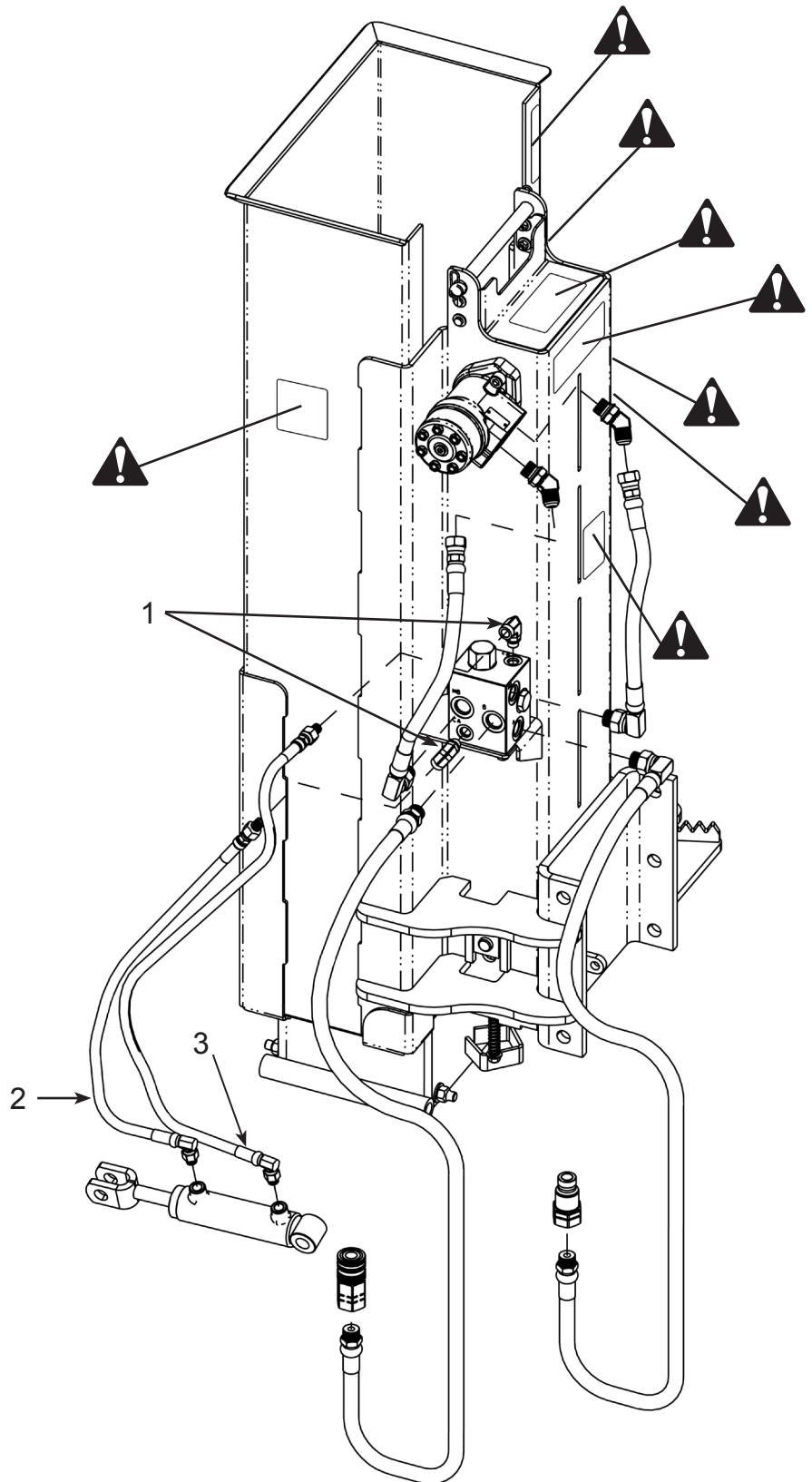

REF. NO.	PART NO.	DESCRIPTION	QTY.
1	21140	#6 O-ring 1/4" Pipe Elbow	2
2	21143	Manifold-Grapple Hydraulic Hose	1
3	21144	Manifold-Grapple Hydraulic Hose	1

Parts

Grapple

 = Safety Sign Location

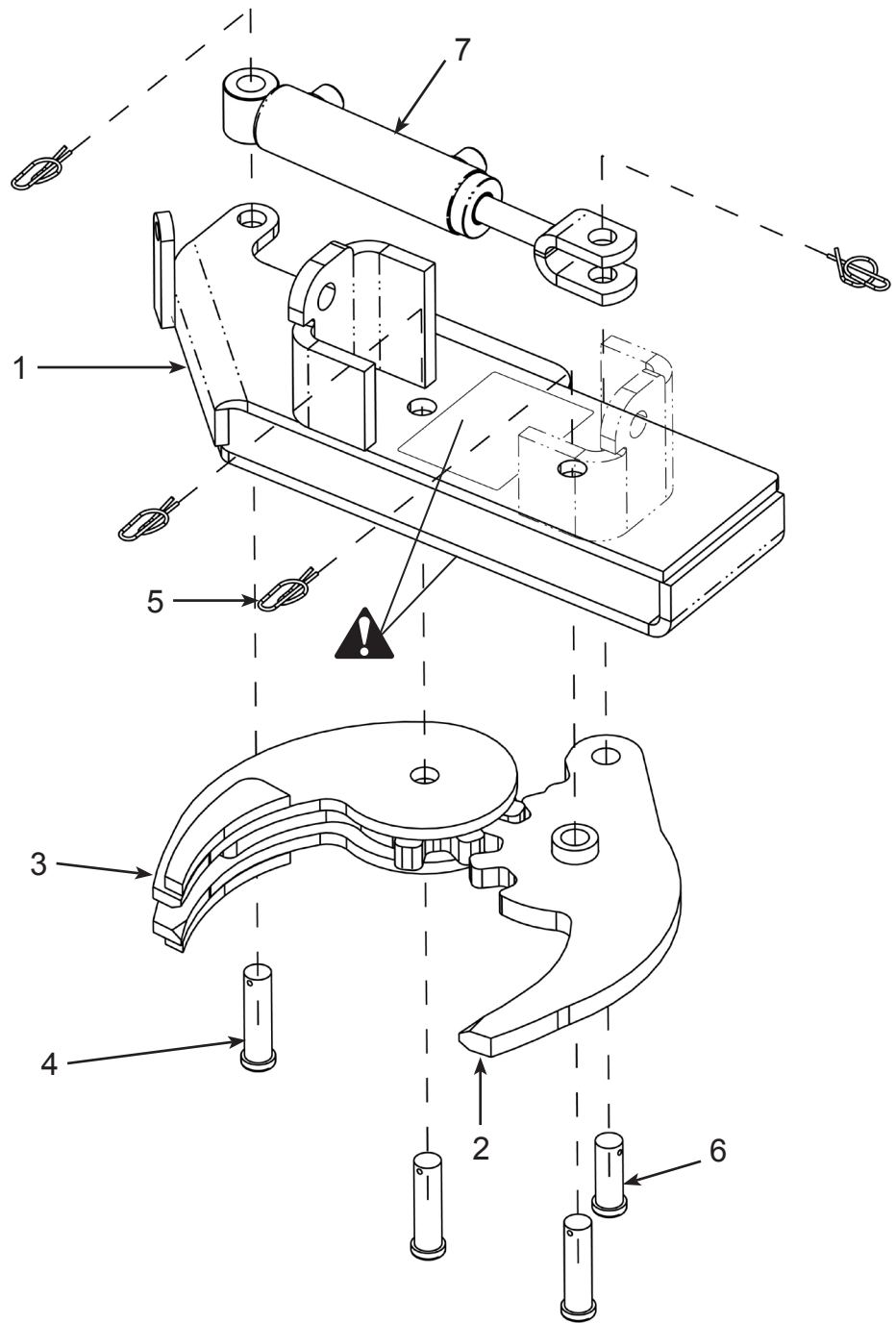

REF. NO.	PART NO.	DESCRIPTION	QTY.
1	21063	Case	1
2	21070	Right Jaw	1
3	21073	Left Jaw	1
4	21077	Clevis Pin	3
5	21078	Rue Clip	4
6	21134	Clevis Pin	1
7	21167	Hydraulic Cylinder	1

Parts

Tilt

 = Safety Sign Location

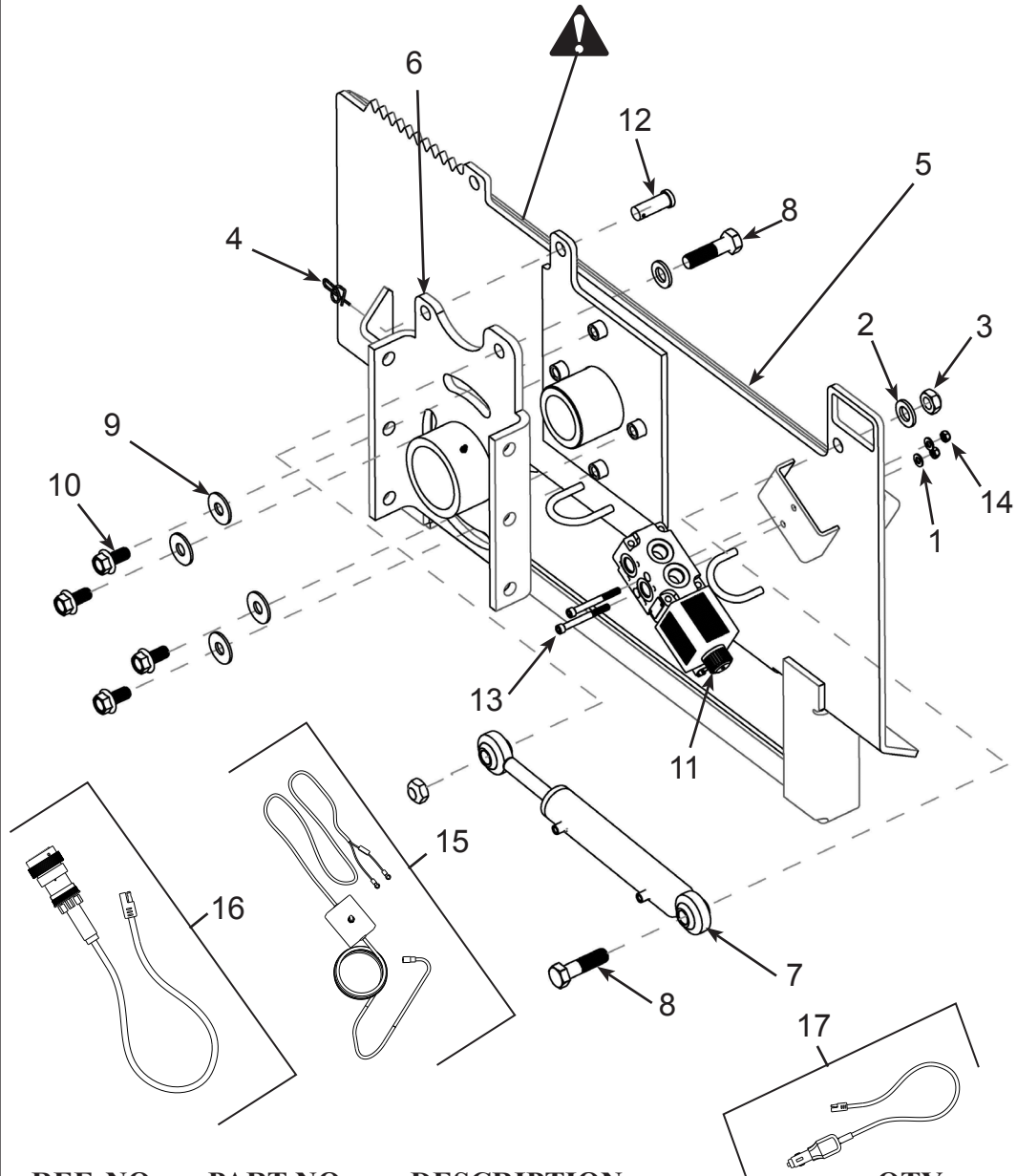

REF. NO.	PART NO.	DESCRIPTION	QTY.
1	6339	5/16" Flat Washer	2
2	10267	3/4" Flat Washer	2
3	10268	Toplock Nut (3/4"-10)	2
4	21078	Rue Clip	1
5	21094	Quick Attach Plate	1
6	21100	Tilt Bracket	1
7	21103	Hydraulic Cylinder	1
8	21106	Bolt (3/4"-10 x 2-3/4")	2
9	21107	5/8" Large Flat Washer	4
10	21108	Flange Bolt (5/8"-11 x 1-1/4", Gr. 8)	4
11	21128	Diverter Valve	1
12	21134	Clevis Pin	1
13	21158	Socket Head Bolt (5/16"-18 x 3")	2
14	21159	Toplock Nut (5/16"-18)	2
15	21162	Wiring Harness	1
16	21220	Wiring Harness 8-Pin	1
	21221	Wiring Harness 14-Pin	
	21222	Wiring Harness 14-Pin Deere	
17	21223	Cigarette Lighter Adapter	1

Decals & Safety Signs



PART NO. DIG21
Location: Unit, left side



PART NO. DANUSER101
Location: Unit, front



PART NO. DIG13
Location: Unit, left side



PART NO. 9875
Location: Drive Unit, front

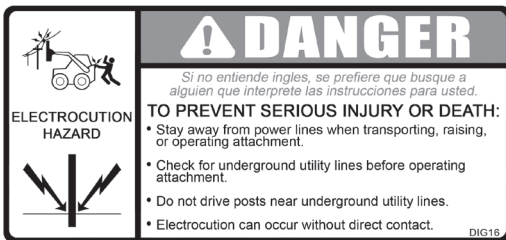

PART NO. DIG16
Location: Unit, left side



HAMMER DECAL
Location: Unit, front

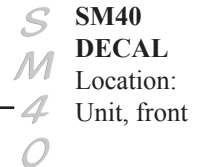

SM40 DECAL
Location: Unit, front

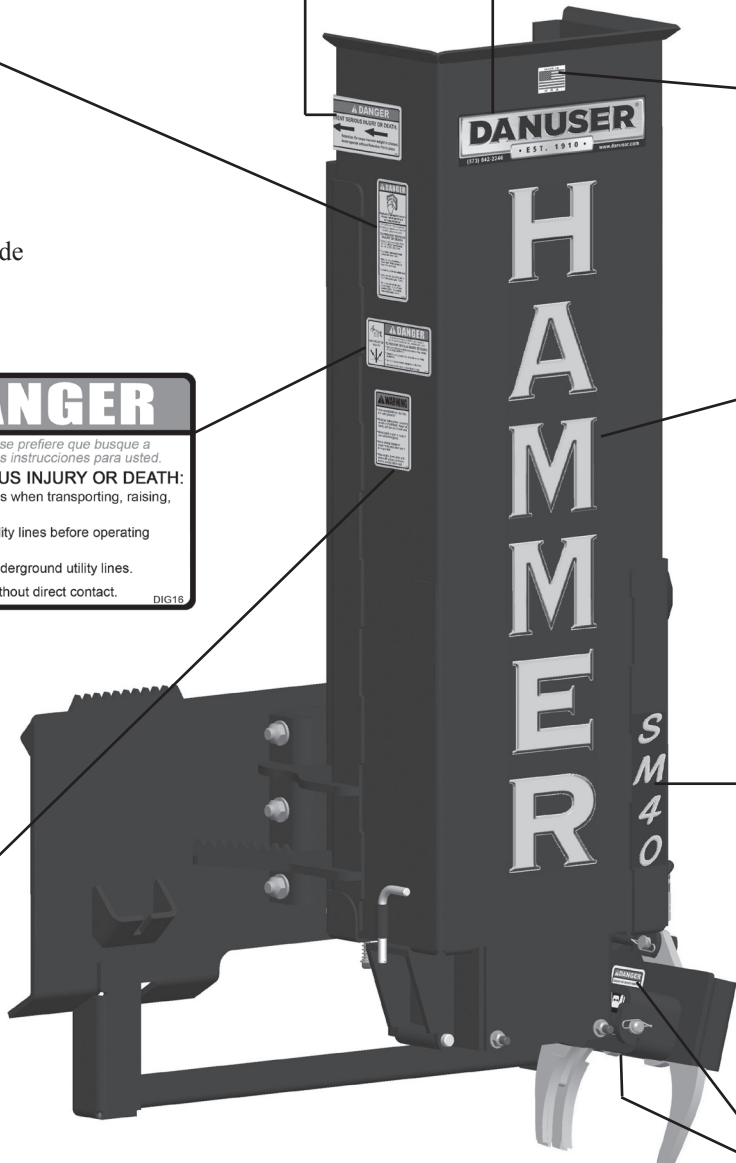

PART NO. DIG14
Location: Unit, left side



Clean or replace all safety signs if they cannot be clearly read and understood.



PART NO. DIG26
Location: Grapple, top & bottom

Decals & Safety Signs

(continued)

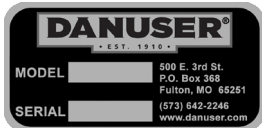

Model No. & Serial No.
Location: Unit, rear



PART NO. DIG5
Location:
Unit, right side



PART NO. DIG22
Location: Unit, rear shelf



PART NO. DIG23
Location: Unit, rear



PART NO. PHDC6
Location: Unit, inside rear



PART NO. DIG24
Location: Unit, rear



Clean or replace all safety signs if they cannot be clearly read and understood.



PART NO. DIG25
Location: Tilt plate

Accessories

 = Safety Sign Location

Tilt PN 21005

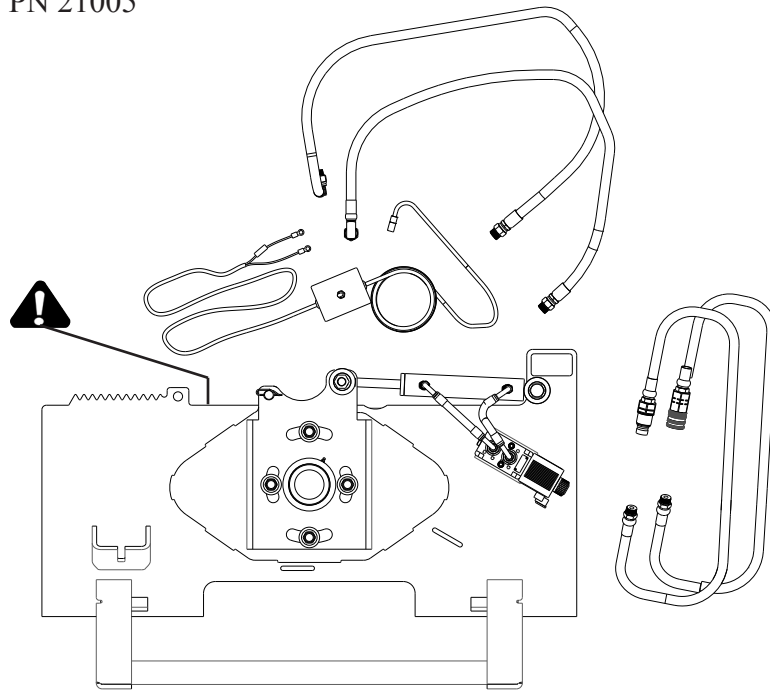

Wiring Harness Options

- PN 21220 - 8 Pin
- PN 21221 - 14 Pin
- PN 21222 - 14 Pin Deere

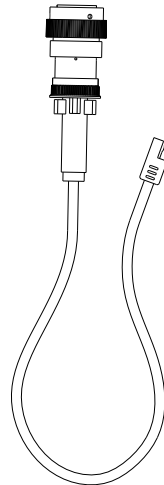

PN 21223 - Cigarette Lighter Adapter

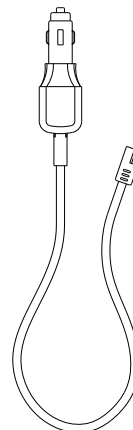

Accessories

(continued)

 = Safety Sign Location

Grapple

PN 21004

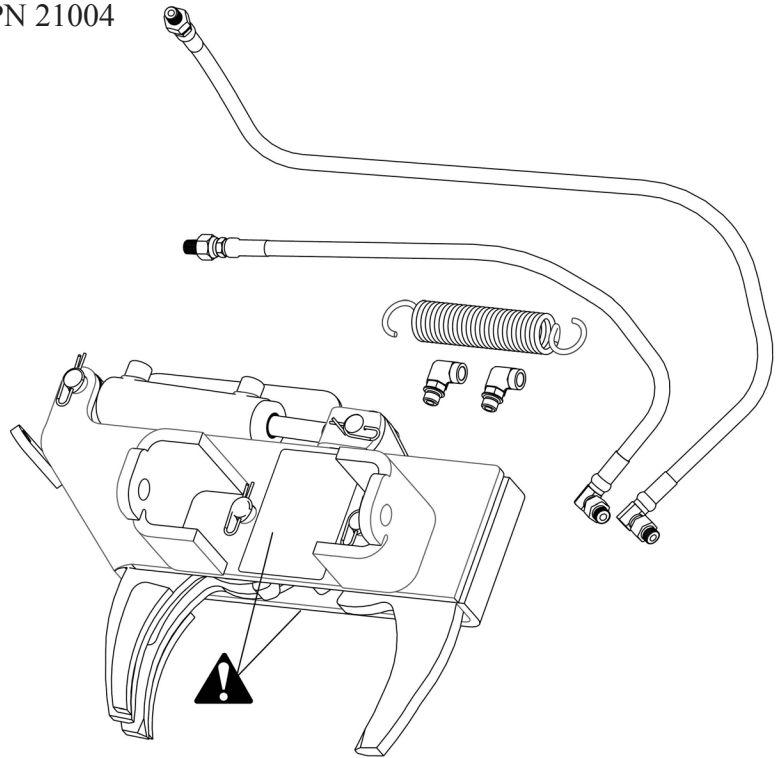

T-Post Adapter

PN 21149

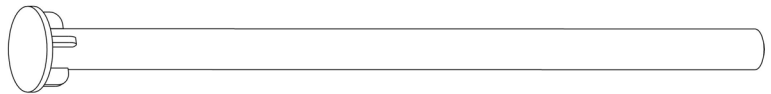

Additional Weight Kit (not shown)

PN 21163

Warranty

DANUSER

Model # _____

LIMITED WARRANTY

Serial # _____

Danuser LLC (“Danuser”) warrants its products, under normal use and maintenance, to be free from defects in material and workmanship for periods specified below from the purchase date from an authorized Danuser Dealer. Start of the warranty period is determined by purchase date given on your returned WARRANTY REGISTRATION FORM. Proof of purchase may be required. This Limited Warranty is extended only to the original purchaser of Danuser products.

Hammer - 1 Year

1. During the applicable warranty period, Danuser, at its option, will repair or replace any part determined by Danuser to be defective. Such repair or replacement shall take place at Danuser’s factory or a location designated by Danuser. Under no circumstances shall Danuser be obligated for the cost of any repair or replacement by anyone other than Danuser without its express written consent.
2. Parts may not be returned without written authorization from Danuser.
3. Some purchased components, including but not limited to hydraulic components are subject to the inspection and warranty of the respective manufacturer. Thus, delays in a warranty determination can be expected while Danuser awaits their decision.
4. This warranty is void if any attempt is made to make field repairs to hydraulic components. To qualify for warranty inspection, the “failed” part must be returned in its original “failed” condition.
5. To make a claim under this warranty, first contact your authorized Danuser Dealer. The Danuser Dealer shall complete the Warranty Claim Form and obtain written authorization from Danuser to return parts. All warranty claims must include detailed information regarding make and model of vehicle on which the Danuser product was mounted, hours of use, description of events that led up to the failure, and any other information helpful in reviewing the warranty claim. All warranty returns must be prepaid. Shipments arriving at our factory on a freight collect basis will be refused by our receiving department. The freight charge will be credited if the parts are determined by Danuser to be defective, and the associated freight costs in returning those parts will be prepaid by Danuser. NOTE: Hydraulic motors must arrive with all ports sealed from dirt and moisture. If a motor arrives with open ports, the warranty is void and no inspection will be made.
6. Products or parts thereof which, as determined by Danuser’s examination, show wear from normal use, have been improperly operated, damaged by accident or negligence, field repaired, altered or modified are not considered defective in material and workmanship and are not covered by this warranty. This warranty does not apply to parts subject to normal wear or to damage caused by the failure to perform recommended maintenance or to replace worn parts. This warranty shall not obligate Danuser to bear any cost of labor for field repair, replacement, testing, or adjustment nor for damage caused by accident, abuse, misuse, or environmental elements.
7. Any parts or labor required to repair or replace parts not covered under this warranty will be charged to the customer. Parts repaired or replaced by Danuser are then covered by this warranty only for the remainder of the original warranty as if such parts were original parts.
8. Danuser reserves the right to change its specifications and designs at any time.

This warranty is exclusive and in lieu of all other express warranties, if any, including the implied warranties of merchantability and fitness for a particular purpose. It shall not extend beyond the duration of the expressed warranty provided herein and the remedy for violations of any implied warranty shall be limited to repair or replacement of the defective part pursuant to the terms contained herein. No employee, dealer, salesman, or representative is authorized to change this warranty in any way or grant any other warranty. Danuser shall not be liable for any consequential, incidental, or punitive damages, losses, or expenses, including those resulting from or caused by any defects.

Danuser LLC
500 E. 3rd St.
P.O. Box 368
Fulton, MO 65251

Tel: (573) 642-2246
Fax: (573) 642-2240
E-mail: sales@danuser.com
Website: www.danuser.com